

STOLL

Ersatzteilliste

Spare parts list

Liste de pièces de rechange

Frontlader Front loaders Chargeurs frontaux

FE 650 P

FE 750 P

FE 850 P

FE 950 P

FE 650 H

FE 750 H

FE 850 H

FE 950 H

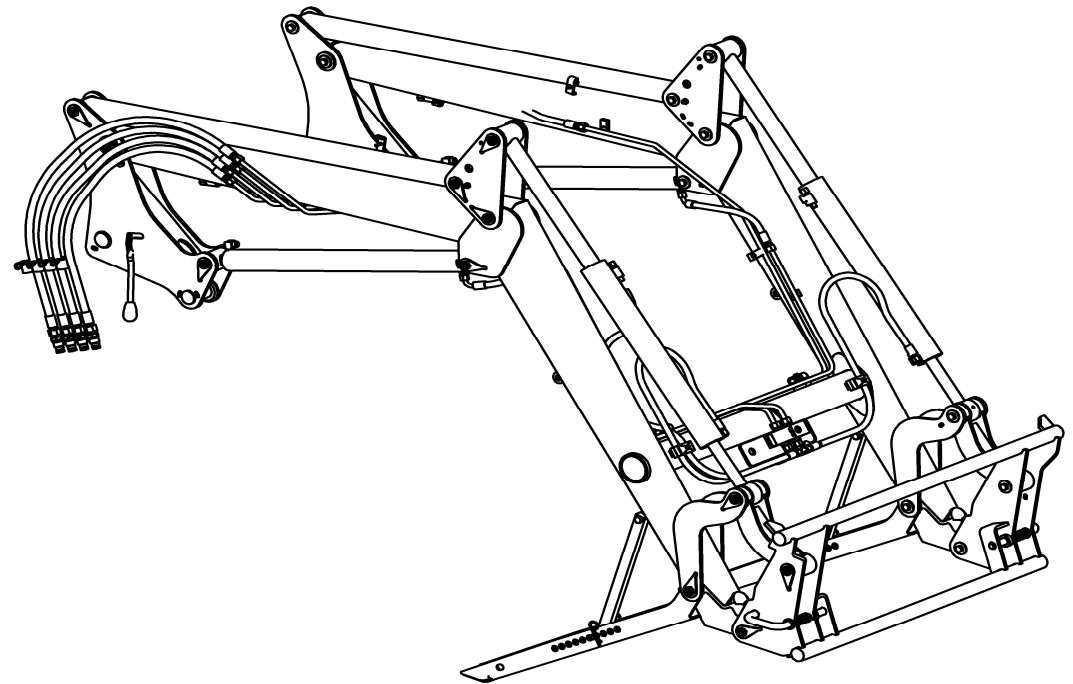

3516070

**Gültig ab Maschinen Nr:
Valid from serial No:
Valable dès N°:**

5003828

P 1521

2013

Bei Ersatzteilbestellungen ist die Fabrikationsnummer Ihrer Maschine unbedingt anzugeben. Das erspart Ihnen Zeit, Geld und Ärger und erleichtert uns die Abfertigung.

Tragen Sie die Nummer Ihrer Maschine bitte hier ein:

Nr: _____ Geliefert am _____

Dann haben Sie bei Ersatzteilbestellungen die Nummer immer zur Hand. Die Fabrikationsnummer ist auf dem Fabrikschild eingetragen, siehe Bild.

Always state the serial number and if possible the year of the machine when ordering spare parts whereby you save time and money and facilitates matters for us.

Please enter the number of your machine here:

Nr: _____ Delivered on the _____

Appropriate when ordering parts. The serial number is located as shown on the figure.

Lorsque vous commandez des pièces de rechange, indiquez toujours le numéro de série de votre machine et si possible son année de fabrication. Vous éviterez des pertes de temps et vous nous faciliterez le travail.

Veillez noter ici le numéro de série de votre chargeur:

Numéro: _____ Livré le _____

Ceci vous sera utile lorsque vous commanderez des pièces. Le Numéro de série est place dans le cadre indiqué sur la figure.



INHALTSVERZEICHNIS	TABLE OF CONTENTS	TABLE DES MATIERES		
Benennung	Description	Désignation	Typ / Type / Type	Seite / Page
Schwinge P	Beam P	Brancard P	FE 650 P FE 750 P FE 850 P FE 950 P	4
Schwinge H	Beam H	Brancard H	FE 650 H FE 750 H FE 850 H FE 950 H	8
Wechselrahmen Euro	Coupler Euro	Bati a Changement Euro	FE 650 P/H FE 750 P/H FE 850 P/H FE 950 P/H	12
Wechselrahmen Skid-Steer	Coupler Skid-Steer	Bati a Cangement Skid-Steer	FE 650 P/H FE 750 P/H FE 850 P/H FE 950 P/H	14
Wechselrahmen SMS	Coupler SMS	Bâti à Changement SMS	FE 650 P/H FE 750 P/H FE 850 P/H FE 950 P/H	16
Wechselrahmen EURO/SMS	Coupler EURO/SMS	Bâti à Changement EURO/SMS	FE 650 P/H FE 750 P/H FE 850 P/H FE 950 P/H	18
Wechselrahmen EURO-ZV	Coupler EURO-ZV	Bâti à Changement EURO-ZV	FE 650 P/H FE 750 P/H FE 850 P/H FE 950 P/H	20
Hydraulik-Ausrüstung	Hydraulik Equipment	Equipement Hydraulique	FE 650 P/H FE 750 P/H	22
Hydraulik-Ausrüstung	Hydraulik Equipment	Equipement Hydraulique	FE 850 P/H FE 950 P/H	24
Hebenzylinder P/H	Lifting cylinder P/H	Vérin de levage P/H	FE 650 P/H FE 750 P/H FE 850 P/H FE 950 P/H	26
Werkzeugzylinder P	Tool actuating cylinder P	Vérin de outil P	FE 650 P FE 750 P FE 850 P FE 950 P	28
Werkzeugzylinder H	Tool actuating cylinder H	Vérin de outil H	FE 650 H FE 750 H FE 850 H FE 950 H	30
Steckkupplungen 3/8"	Plug in coupling 3/8"	Connexion hydraulique 3/8"	FE 650 P/H FE 750 P/H FE 850 P/H FE 950 P/H	32
Hydro-Fix	Hydro-Fix	Hydro-Fix	FE 650 P/H FE 750 P/H FE 850 P/H FE 950 P/H	34
Dichtsatz für Hydro-Fix	Seal kit for Hydro-Fix	Jeu de joints de Hydro-Fix	FE 650 P/H FE 750 P/H FE 850 P/H FE 950 P/H	36
Wegeventile Übersicht	Control valves, summary	Valves de commande, vue d'ensemble	FE 650 P/H FE 750 P/H FE 850 P/H FE 950 P/H	37
Ventil	Valve	Valve	FE 650 P/H FE 750 P/H FE 850 P/H FE 950 P/H	38
Dichtsatz für Wegeventil Nimco	Seal kit for control valve Nimco	Jeu de joints pour bloc de commande Nimco	FE 650 P/H FE 750 P/H FE 850 P/H FE 950 P/H	40
Dichtsatz für Wegeventil Walvoil	Seal Kit for control valve Walvoil	Jeu de joints pour bloc de commande Walvoil	FE 650 P/H FE 750 P/H FE 850 P/H FE 950 P/H	42
Dichtsatz für Wegeventil 45 l/min	Seal kit for control valve 45 l/min	Jeu de joints pour bloc de commande 45 l/min	FE 650 P/H FE 750 P/H FE 850 P/H FE 950 P/H	44
Einhebelsteuergerät	Single-lever Control unit	Monolevier	FE 650 P/H FE 750 P/H FE 850 P/H FE 950 P/H	46
Ausrüstung Comfort-Drive	Kit Comfort-Drive	Comfort-Drive équipement	FE 650 P/H FE 750 P/H FE 850 P/H FE 950 P/H	48
Hydraulik-Ausrüstung 3. Steuerkreis	Hydraulik Equipment 3rd Function	Equipement hydraulique 3ème Fonction	FE 650 P/H FE 750 P/H FE 850 P/H FE 950 P/H	50
Elektroausrüstung FE	Electrical equipment FE	Equipement électrique FE	FE 650 P/H FE 750 P/H FE 850 P/H FE 950 P/H	52
Aufkleber Anleitung	Decal Manual	Autocollants Instruction	FE 650 P/H FE 750 P/H FE 850 P/H FE 950 P/H	54
Aufkleber Anleitung	Decal Manual	Autocollants Instruction	FE 650 P/H FE 750 P/H FE 850 P/H FE 950 P/H	56

STOLL FE

DE Schwinge P

FE 650 P
 FE 750 P
 FE 850 P
 FE 950 P

EN Beam P

FE 650 P
 FE 750 P
 FE 850 P
 FE 950 P

FR Brancard P

FE 650 P
 FE 750 P
 FE 850 P
 FE 950 P

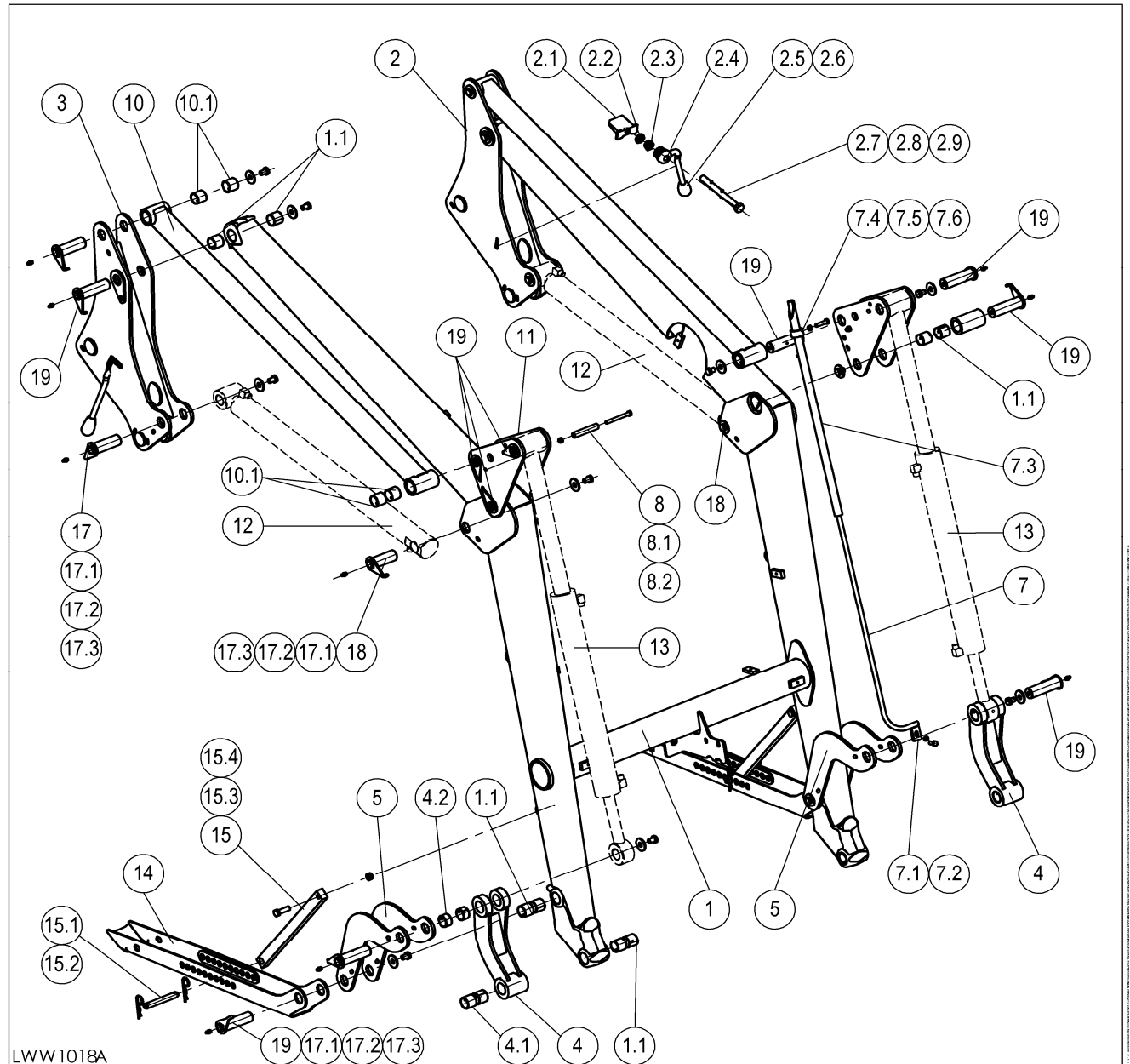

LWW1018A

LWW 1018		Schwinge P	Beam P	Brancard P	STOLL FE	FE 650 P	FE 750 P	FE 850 P	FE 950 P
Pos.	Bestell-Nr.	Benennung	Description	Désignation	Zeichnungsnr.	SIZE/MASS			
1	3501670	Schwinge gsw	Beam welded	Brancard soudé	58.804-21		1		
1	3489780	Schwinge gsw	Beam welded	Brancard soudé	58.800-21			1	
1	3503840	Schwinge gsw	Beam welded	Brancard soudé	58.810-21				1
1	3503920	Schwinge gsw	Beam welded	Brancard soudé	58.820-21				1
1.1	0481980	Verbundstoffbuchse	Bush	Douille		IHG PM 3030 DX	16	16	16
2	3490330	Säule li	Column LH	Pilier gauche	58.800-03		1	1	1
2.1	3493100	Keil	Chock	Clavette	58.800-03-02		2	2	2
2.2	0443870	Sechskantmutter	Hex nut	Ecrou	ISO 8675	BM16x1.5	2	2	2
2.3	0421610	Kronenmutter	castellated nut	Ecrou	DIN 979	M16x1.5	2	2	2
2.4	0453520	Tellerfeder	Cup spring	Rondelle ressort	DIN 2093	C31.5	16	16	16
2.5	1306470	Griffbolzen	Grip bolt	Axe d'accrochage	55.69-01-02		2	2	2
2.6	1429180	Halbrundgriff	Handle	Prise		M10 SW	2	2	2
2.7	3447700	Gewindebolzen	Threaded bolt	Goujon fileté	58.725-03-01-00.1		2	2	2
2.8	0012440	Spannstift	Spring-type straight pin	Goupille	ISO 8652	4x28	2	2	2
2.9	0405610	Spannstift	Spring-type straight pin	Goupille	ISO 8653	5x28	2	2	2
3	3490340	Säule re	Column RH	Pilier droite	58.800-04		1	1	1
4	3490520	Doppelhebel	Double lever	Levier double	58.800-06		2	2	2
4.1	0481980	Verbundstoffbuchse	Bush	Douille		IHG PM 3030 DX	4	4	4
4.2	0483560	Verbundstoffbuchse	Bush	Douille		IHG PM 3020 DX	4	4	4
5	3490590	Hebel	Lever	Levier	58.800-00.2		4	4	4
7	3308150	Sichtanzeige	Indicator	Indication a vue	58.428-01-12	1343	1	1	
7	3308180	Sichtanzeige	Indicator	Indication a vue	58.453-01-04	1593			1
7.1	0482210	Sechskantschraube	Hex bolt	Vis	ISO 8676	M8 x1.0x20	1	1	1
7.2	0452140	Sicherheitsring	Safety ring	Bague de sécurité	DIN 127	A 08	1	1	1
7.3	0381730	Rohr	Pipe	Tuyau	58.10-18.1		1	1	1
7.4	2361590	Buchse	Bush	Douille	58.157-00.1		1	1	1
7.5	0202200	Sechskantschraube	Hex bolt	Vis		M8x35	1	1	1
7.6	0200600	Sicherungsmutter	Lock nut	Ecrou autofreiné		NM8	1	1	1
8	3504350	Buchse	Bush	Douille	58.800-00.3		2	2	2
8.1	0060590	Sechskantschraube	Hex bolt	Vis		M8x100	2	2	2
8.2	0200600	Sicherungsmutter	Lock nut	Ecrou autofreiné		NM8	2	2	2
10	3501120	Steuerstange	Push-Rod	Barre guidée	58.804-05	1105	2	-	-
10	3490280	Steuerstange	Push-Rod	Barre guidée	58.800-05	1220		2	2
10	2483590	Steuerstange	Push-Rod	Barre guidée	58.478-01-02	1370			2
10.1	0481980	Verbundstoffbuchse	Bush	Douille		IHG PM 3030 DX	8	8	8
11	3490570	Umlenkhebel	Lever	Levier	58.800-00.1		4	4	4

STOLL FE

DE Schwinge P

EN Beam P

FR Brancard P

- FE 650 P
- FE 750 P
- FE 850 P
- FE 950 P

- FE 650 P
- FE 750 P
- FE 850 P
- FE 950 P

- FE 650 P
- FE 750 P
- FE 850 P
- FE 950 P

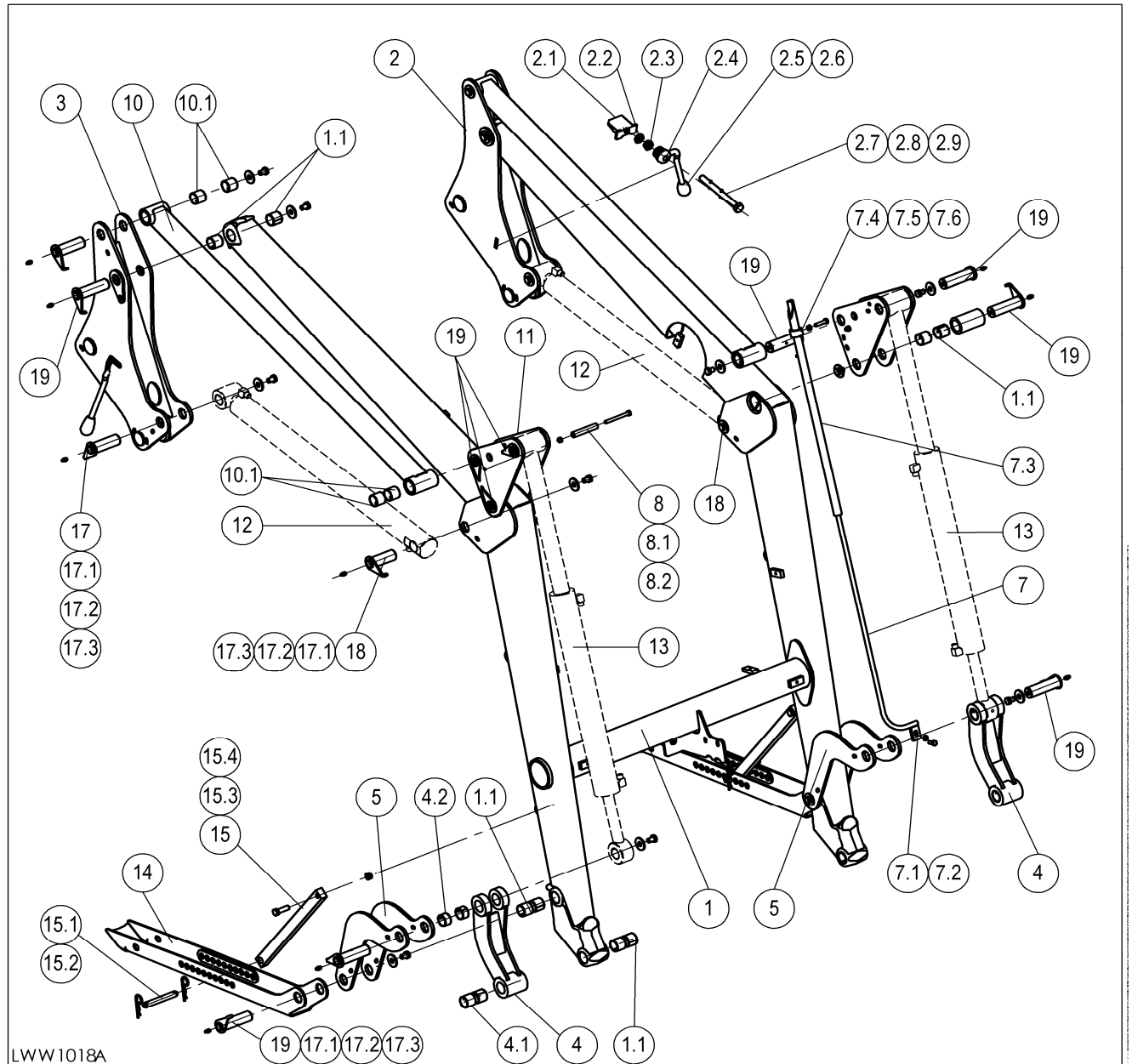

LWW 1018		Schwinge P	Beam P	Brancard P	STOLL FE		FE 650 P	FE 750 P	FE 850 P	FE 950 P
Pos.	Bestell-Nr.	Benennung	Description	Désignation	Zeichnungsnr.	SIZE/MASS				
12	3490630	Hebenzylinder	Cylinder Beam	Vérin de levage	58.02-170	50/30/760/605	2			
12	3490670	Hebenzylinder	Cylinder Beam	Vérin de levage	58.02-171	55/35/850/640		2		
12	3490680	Hebenzylinder	Cylinder Beam	Vérin de levage	58.02-172	60/35/850/640			2	
12	3490682	Hebenzylinder	Cylinder Beam	Vérin de levage	58.02-172 B	60/35/850/640			2	
12	3490690	Hebenzylinder	Cylinder Beam	Vérin de levage	58.02-173	65/35/850/640				2
13	3490710	Werkzeugzylinder	Cylinder Bucket	Vérin d' outil	58.02-180	55/30/1030/405	2			
13	3490720	Werkzeugzylinder	Cylinder Bucket	Vérin d' outil	58.02-181	60/30/1100/440		2		
13	3490730	Werkzeugzylinder	Cylinder Bucket	Vérin d' outil	58.02-182	60/30/1230/500			2	
13	3490700	Werkzeugzylinder	Cylinder Bucket	Vérin d' outil	58.02-183	65/35/1310/540				2
14	3501180	Abstellstütze	Supporting leg	Béquille	58.804-17-01	743	2			
14	3501150	Abstellstütze	Supporting leg	Béquille	58.800-17-01	851		2	2	2
15	3501290	Arretierung	Locking	Dispositif d' arret	58.804-17-00.1	370	2			
15	3501280	Arretierung	Locking	Dispositif d' arret	58.800-17-00.1	430		2	2	2
15.1	3501720	Stecker	Clip	Connecteur	58.804-17-00.2	Ø 6x115 mm	2	2	2	2
15.2	0297740	Federstecker	Spring cotter	Goupille á ressort	D 11024	Federstecker 4	4	4	4	4
15.3	0202270	Sechskantschraube	Hex bolt	Vis	D 933	M12x40	2	2	2	2
15.4	0200610	Sicherungsmutter	Lock nut	Ecrou autofreiné	D 985	NM 12	2	2	2	2
17	3501400	Bolzen	Bolt	Boulon	58.800-11	Ø 30x87,8 mm	4	4	4	4
17.1	1404310	Sechskantschraube	Hex bolt	Vis	D 933	M12x16	18	18	18	18
17.2	0014070	Scheibe	Plain washer	Rondelle	D 9021	A13	18	18	18	18
17.3	0406590	Schmiernippel	Grease nipple	Graisser		AS8x1	18	18	18	18
18	3501430	Bolzen	Bolt	Boulon	58.800-12	Ø 30x77,8 mm	2	2	2	2
19	3501450	Bolzen	Bolt	Boulon	58.800-13	Ø 30x99,3 mm	12	12	12	12

STOLL FE

DE SCHWINGE H

EN BEAM H

FR BRANCARD H

- FE 650 H
- FE 750 H
- FE 850 H
- FE 950 H

- FE 650 H
- FE 750 H
- FE 850 H
- FE 950 H

- FE 650 H
- FE 750 H
- FE 850 H
- FE 950 H

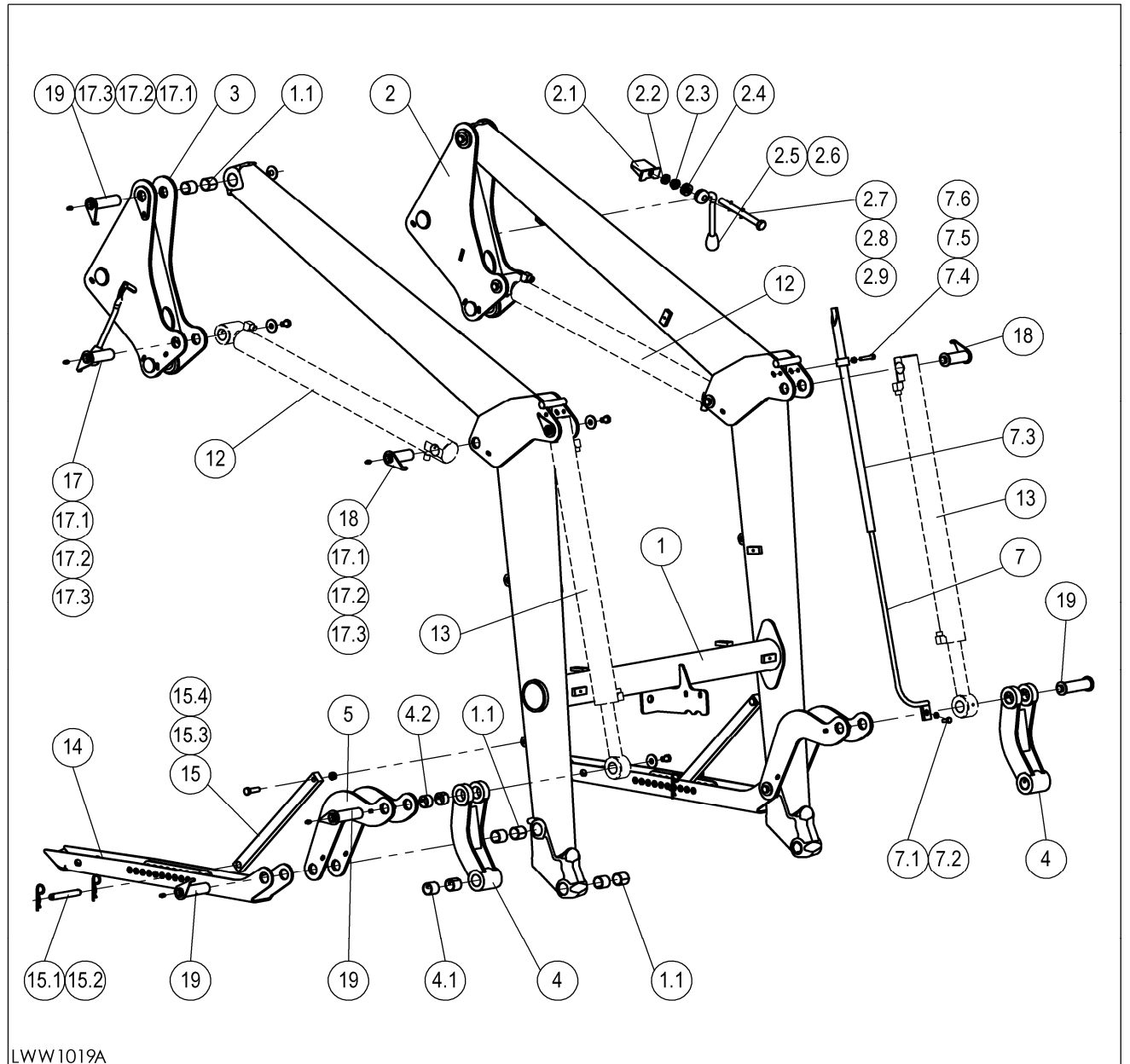

LWW1019A

LWW 1019		Schwinge H	Beam H	Brancard H	STOLL FE	FE 650 H	FE 750 H	FE 850 H	FE 950 H
Pos.	Bestell-Nr.	Benennung	Description	Désignation	Zeichnungsnr.	SIZE/MASS			
1	3501700	Schwinge gsw	Beam welded	Brancard soudé	58.805-21		1		
1	3489880	Schwinge gsw	Beam welded	Brancard soudé	58.801-21			1	
1	3504270	Schwinge gsw	Beam welded	Brancard soudé	58.811-21				1
1	3504320	Schwinge gsw	Beam welded	Brancard soudé	58.821-21				1
1.1	0481980	Verbundstoffbuchse	Bush	Douille		IHG PM 3030 DX	12	12	12
2	3501300	Säule li	Column LH	Pilier gauche	58.801-03		1	1	1
2.1	3493100	Keil	Chock	Clavette	58.800-03-02		2	2	2
2.2	0443870	Sechskantmutter	Hex nut	Ecrou	ISO 8675	BM16x1.5	2	2	2
2.3	0421610	Kronenmutter	castellated nut	Ecrou	DIN 979	M16x1.5	2	2	2
2.4	0453520	Tellerfeder	Cup spring	Rondelle ressort	DIN 2093	C31.5	16	16	16
2.5	1306470	Griffbolzen	Grip bolt	Axe d'accrochage	55.69-01-02		2	2	2
2.6	1429180	Halbrundgriff	Handle	Prise		M10 SW	2	2	2
2.7	3447700	Gewindebolzen	Threaded bolt	Goujon fileté	58.725-03-01-00.1		2	2	2
2.8	0012440	Spannstift	Spring-type straight pin	Goupille	ISO 8652	4x28	2	2	2
2.9	0405610	Spannstift	Spring-type straight pin	Goupille	ISO 8653	5x28	2	2	2
3	3501310	Säule re	Column RH	Pilier droite	58.801-04		1	1	1
4	3490520	Doppelhebel	Double lever	Levier double	58.800-06		2	2	2
4.1	0481980	Verbundstoffbuchse	Bush	Douille		IHG PM 3030 DX	4	4	4
4.2	0483560	Verbundstoffbuchse	Bush	Douille		IHG PM 3020 DX	4	4	4
5	3490590	Hebel	Lever	Levier	58.800-00.2		4	4	4
7	2361820	Sichtanzeige	Indicator	Indication a vue	58.157-08	1193	1	1	1
7.1	0482210	Sechskantschraube	Hex bolt	Vis	ISO 8676	M8 x1.0x20	1	1	1
7.2	0452140	Sicherheitsring	Safety ring	Bague de securité	DIN 127	A 08	1	1	1
7.3	0381730	Rohr	Pipe	Tuyau	58.10-18.1		1	1	1
7.4	2361590	Buchse	Bush	Douille	58.157-00.1		1	1	1
7.5	0081590	Sechskantschraube	Hex bolt	Vis		M8x45	1	1	1
7.6	0200600	Sicherungsmutter	Lock nut	Ecrou autofreiné		NM8	1	1	1
11	3490570	Umlenkhebel	Lever	Levier	58.800-00.1		4	4	4
12	3490630	Hebenzylinder	Cylinder Beam	Vérin de levage	58.02-170	50/30/760/605	2		
12	3490670	Hebenzylinder	Cylinder Beam	Vérin de levage	58.02-171	55/35/850/640		2	
12	3490680	Hebenzylinder	Cylinder Beam	Vérin de levage	58.02-172	60/35/850/640			2
12	3490682	Hebenzylinder	Cylinder Beam	Vérin de levage	58.02-172 B	60/35/850/640			2
12	3490690	Hebenzylinder	Cylinder Beam	Vérin de levage	58.02-173	65/35/850/640			2
13	3490740	Werkzeugzylinder	Cylinder Bucket	Vérin d' outil	58.02-190	55/35/850/640	2	2	
13	3490750	Werkzeugzylinder	Cylinder Bucket	Vérin d' outil	58.02-192	60/35/850/640			2
14	3501180	Abstellstütze	Supporting leg	Béquille	58.804-17-01	743	2		
14	3501150	Abstellstütze	Supporting leg	Béquille	58.800-17-01	851		2	2

STOLL FE

DE SCHWINGE H

EN BEAM H

FR BRANCARD H

- FE 650 H
- FE 750 H
- FE 850 H
- FE 950 H

- FE 650 H
- FE 750 H
- FE 850 H
- FE 950 H

- FE 650 H
- FE 750 H
- FE 850 H
- FE 950 H

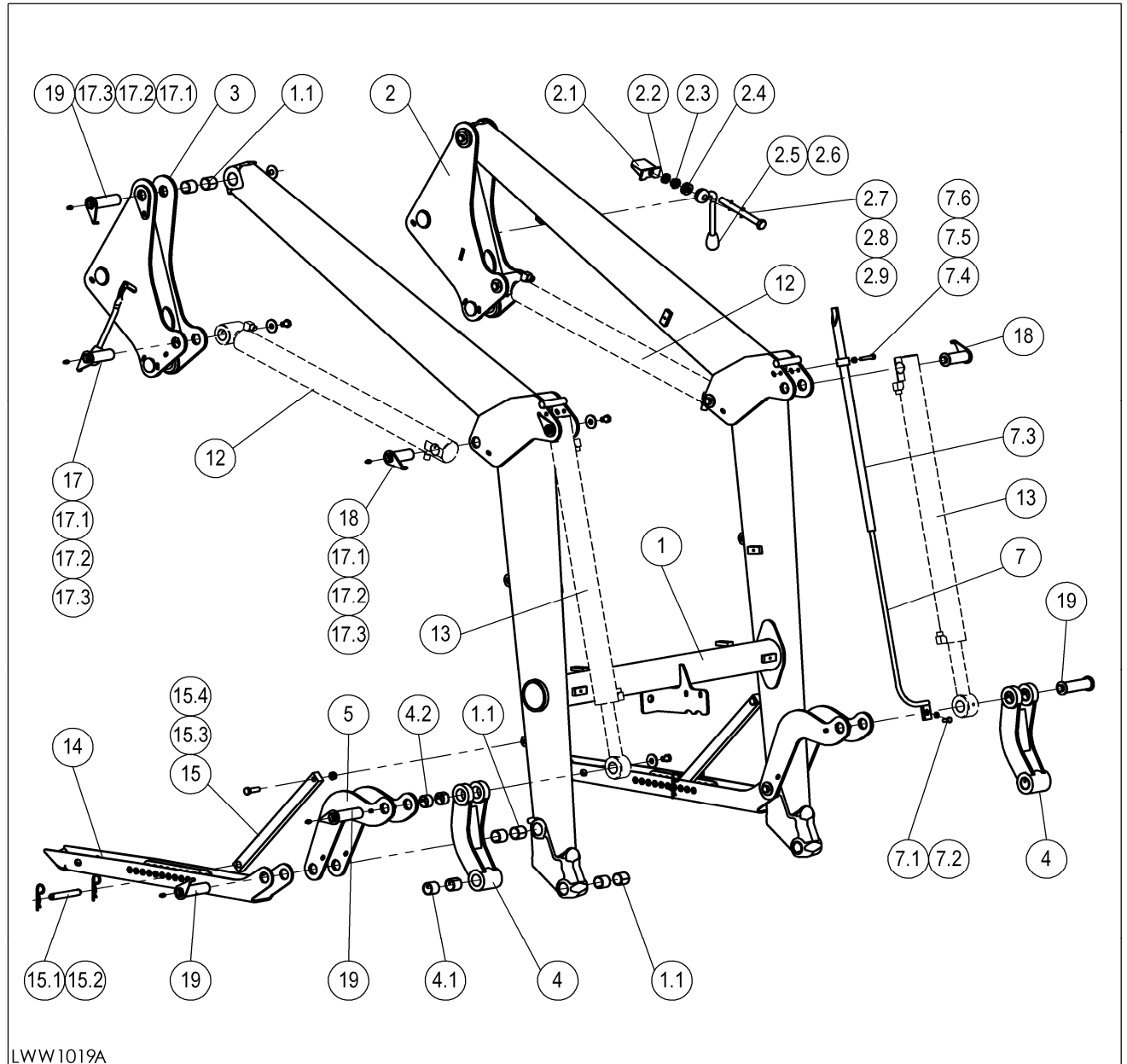

LWW1019A

LWW 1019		Schwinge H	Beam H	Brancard H	STOLL FE	FE 650 H	FE 750 H	FE 850 H	FE 950 H
Pos.	Bestell-Nr.	Benennung	Description	Désignation	Zeichnungsnr.	SIZE/MASS			
15	3501290	Arretierung	Locking	Dispositif d' arret	58.804-17-00.1	370	2		
15	3501280	Arretierung	Locking	Dispositif d' arret	58.800-17-00.1	430		2	2
15.1	3501720	Stecker	Clip	Connecteur	58.804-17-00.2	Ø 6x115 mm	2	2	2
15.2	0297740	Federstecker	Spring cotter	Goupille á ressort	D 11024	Federstecker 4	4	4	4
15.3	0202270	Sechskantschraube	Hex bolt	Vis	D 933	M12x40	2	2	2
15.4	0200610	Sicherungsmutter	Lock nut	Ecrou autofreiné	D 985	NM 12	2	2	2
17	3501400	Bolzen	Bolt	Boulon	58.800-11	Ø 30x87,8 mm	2	2	2
17.1	1404310	Sechskantschraube	Hex bolt	Vis	D 933	M12x16	12	12	12
17.2	0014070	Scheibe	Plain washer	Rondelle	D 9021	A13	12	12	12
17.3	0406590	Schmiernippel	Grease nipple	Graisieur		AS8x1	12	12	12
18	3501430	Bolzen	Bolt	Boulon	58.800-12	Ø 30x77,8 mm	4	4	4
19	3501450	Bolzen	Bolt	Boulon	58.800-13	Ø 30x99,3 mm	6	6	6

STOLL FE

DE Wechselrahmen
Euro

FE 650 P/H
FE 750 P/H
FE 850 P/H
FE 950 P/H

EN Coupler Euro

FE 650 P/H
FE 750 P/H
FE 850 P/H
FE 950 P/H

FR Bati a Changement
Euro

FE 650 P/H
FE 750 P/H
FE 850 P/H
FE 950 P/H

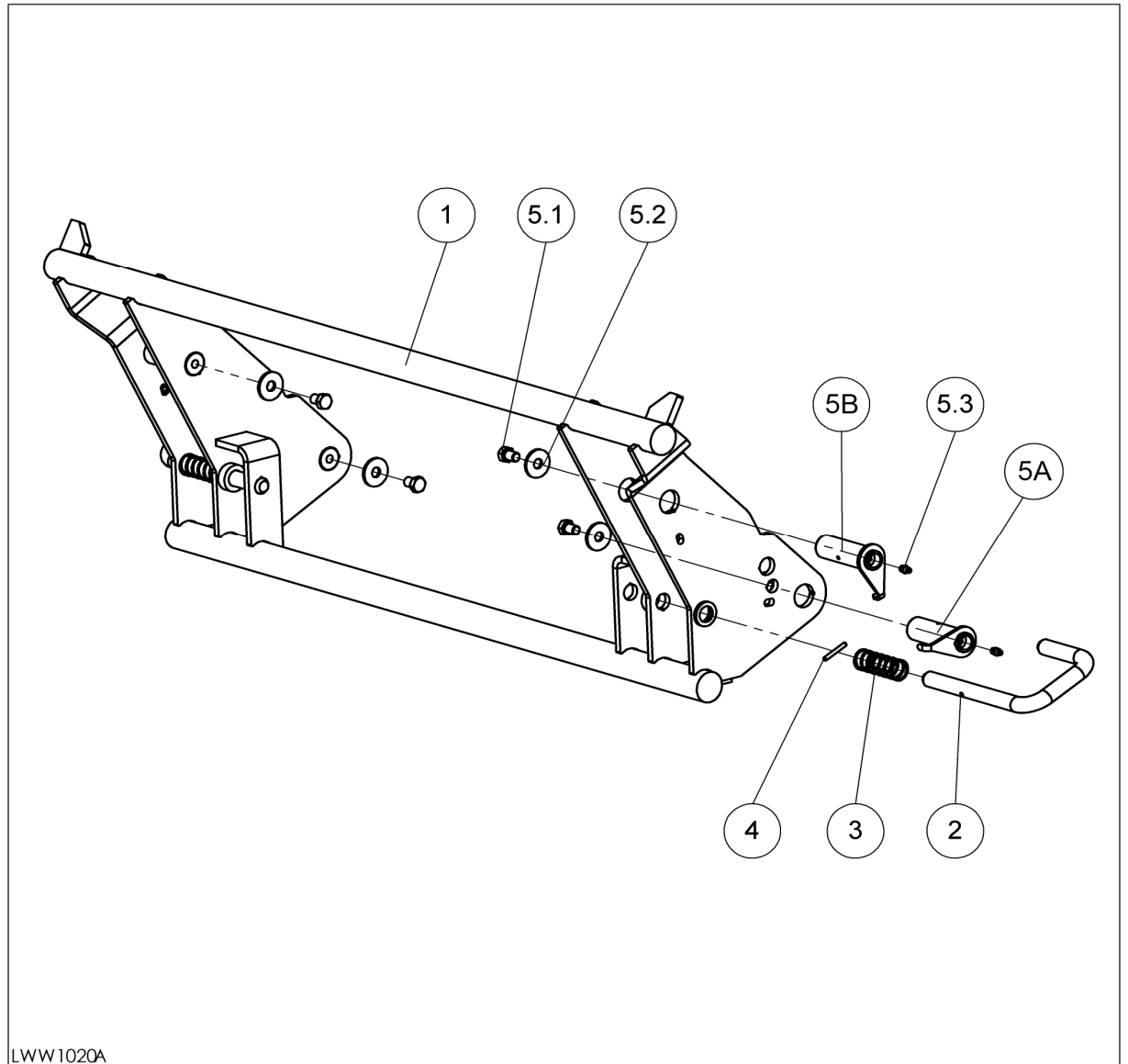

LWW1020A

LWW 1020		Wechselrahmen Euro	Coupler Euro	Bati a Changement Euro	STOLL FE	FE 650 P	FE 650 H	FE 750 P	FE 750 H	FE 850 P	FE 850 H	FE 950 P	FE 950 H
Pos.	Bestell-Nr.	Benennung	Description	Désignation	Zeichnungsnr. SIZE/MASS								
1	3490410	Wechselrahmen gsw	Frame coupler	Bâti à Changement soudé	58.800-02	1	1	1	1	1	1	1	1
2	3490500	Stecker	Clip	Connecteur	58.800-02-00.1	2	2	2	2	2	2	2	2
3	3490510	Druckfeder	Pressure spring	Ressort de pression	58.800-02-00.2	2	2	2	2	2	2	2	2
4	0013090	Spannstift	Spring-type straight pin	Goupille	ISO 8752 5x36	2	2	2	2	2	2	2	2
5A	3501450	Bolzen	Bolt	Boulon	58.800-13 ø30 x 99,3	2	2	2	2	2	2	2	2
5B	3501400	Bolzen	Bolt	Boulon	58.800-11 ø30 x 87,8	2	2	2	2	2	2	2	2
5.1	1404310	Sechskantschraube	Hex bolt	Vis	D 933 M12x16	4	4	4	4	4	4	4	4
5.2	0014070	Scheibe	Plain washer	Rondelle	D 9021 A13	4	4	4	4	4	4	4	4
5.3	0406590	Schmiernippel	Grease nipple	Graisneur	AS8x1	4	4	4	4	4	4	4	4

STOLL FE

DE Wechselrahmen
Skid-Steer

FE 650 P/H
FE 750 P/H
FE 850 P/H
FE 950 P/H

EN Coupler
Skid-Steer

FE 650 P/H
FE 750 P/H
FE 850 P/H
FE 950 P/H

FR Bati a Cangement
Skid-Steer

FE 650 P/H
FE 750 P/H
FE 850 P/H
FE 950 P/H

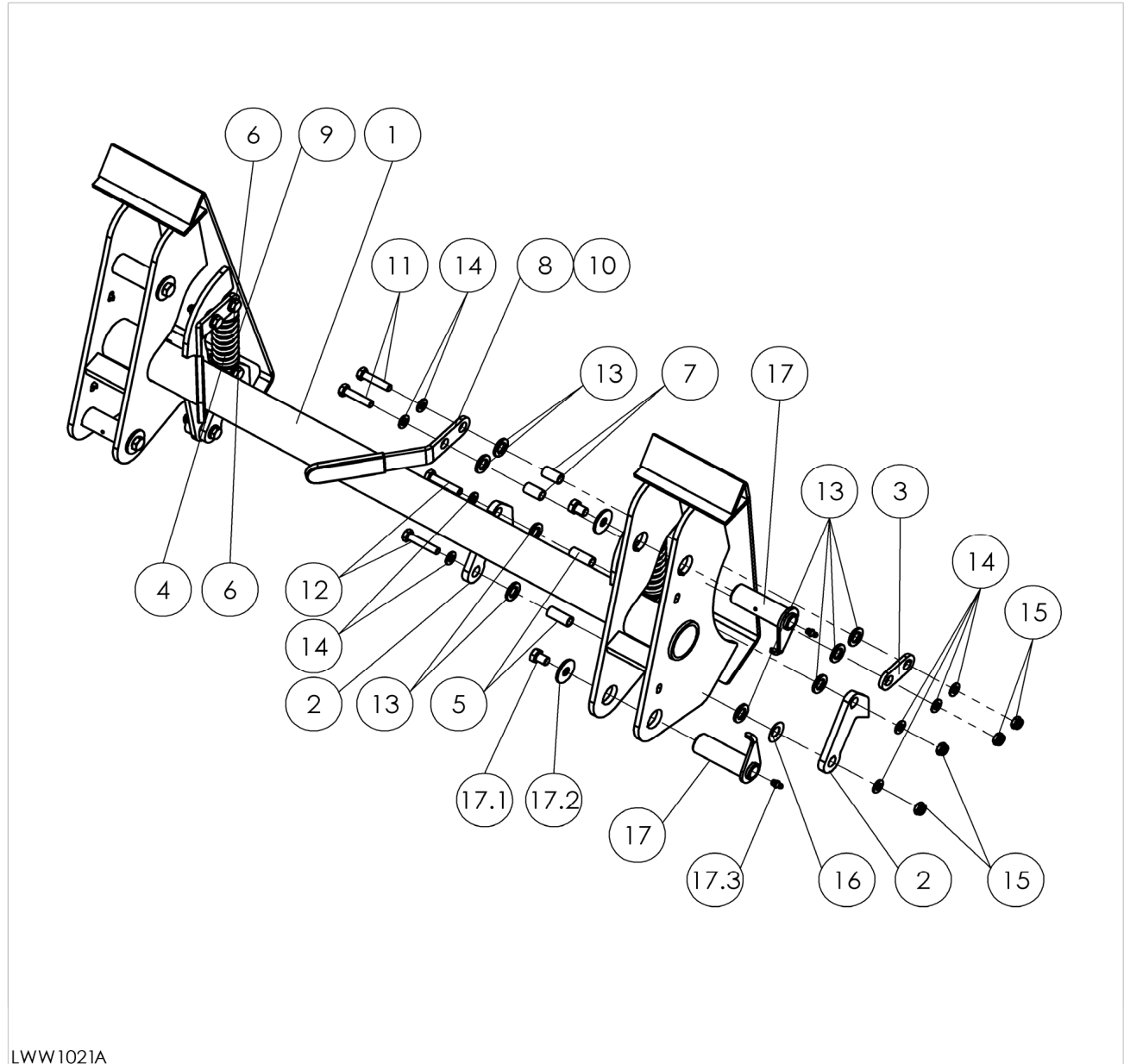

LWW1021A

LWW 1021		Wechselrahmen Skid-Steer	Coupler Steer	Skid- Bati a Cangement Skid-Steer	STOLL FE	FE 650 P	FE 650 H	FE 750 P	FE 750 H	FE 850 P	FE 850 H	FE 950 P	FE 950 H
Pos.	Bestell-Nr.	Benennung	Description	Désignation	Zeichnungsnr	SIZE/MASS							
1	3491510	Wechselrahmen gsw	Frame coupler	Bati a Cangement soudé	58.800-22-01		1	1	1	1	1	1	1
2	3493460	Haken	Hook	crochet	58.765-02-00.1		4	4	4	4	4	4	4
3	3493470	Lasche	Buttstrap	Éclisse	58.765-02-00.2		2	2	2	2	2	2	2
4	3493480	Verbindungsstrebe	Linkage bar	Traverse de jonction	58.765-02-00.3		2	2	2	2	2	2	2
5	3493490	Buchse	Bush	Douille	58.765-02-00.4		4	4	4	4	4	4	4
6	3493500	Scheibe	Plain washer	Rondelle	58.765-02-00.5		4	4	4	4	4	4	4
7	3493510	Buchse	Bush	Douille	58.765-02-00.6		4	4	4	4	4	4	4
8	3493520	Hebel	Lever	Levier	58.765-02-00.7		2	2	2	2	2	2	2
9	1431910	Druckfeder	Pressure spring	Ressort de pression	VD-356A	5x32x94	2	2	2	2	2	2	2
10	1427780	Griff	Handle	Prise			2	2	2	2	2	2	2
11	0071620	Sechskantmutter	Hex nut	Ecrou	DIN 931	M10x45	4	4	4	4	4	4	4
12	0416820	Sechskantmutter	Hex nut	Ecrou	DIN 931	M10x50	4	4	4	4	4	4	4
13	0011990	Scheibe	Plain washer	Rondelle	DIN 1441	17	16	16	16	16	16	16	16
14	0407400	Scheibe	Plain washer	Rondelle	DIN 125	A 10,5	16	16	16	16	16	16	16
15	0011940	Sicherungsmutter	Lock nut	Ecrou autofreiné	DIN 985	NM10	8	8	8	8	8	8	8
16	0453520	Tellerfeder	Cup spring	Rondelle ressort	DIN 2093	C31,5	2	2	2	2	2	2	2
17	3501400	Bolzen	Bolt	Boulon	58.800-11	ø30 x 87,7	4	4	4	4	4	4	4
17.1	1404310	Sechskantschraube	Hex bolt	Vis	D 933	M12x16	4	4	4	4	4	4	4
17.2	0014070	Scheibe	Plain washer	Rondelle	D 9021	A13	4	4	4	4	4	4	4
17.3	0406590	Schmiernippel	Grease nipple	Graisneur		AS8x1	4	4	4	4	4	4	4

STOLL FE

DE Wechselrahmen SMS

FE 650 P/H
FE 750 P/H
FE 850 P/H
FE 950 P/H

EN Coupler SMS

FE 650 P/H
FE 750 P/H
FE 850 P/H
FE 950 P/H

FR Bâti à Changement SMS

FE 650 P/H
FE 750 P/H
FE 850 P/H
FE 950 P/H

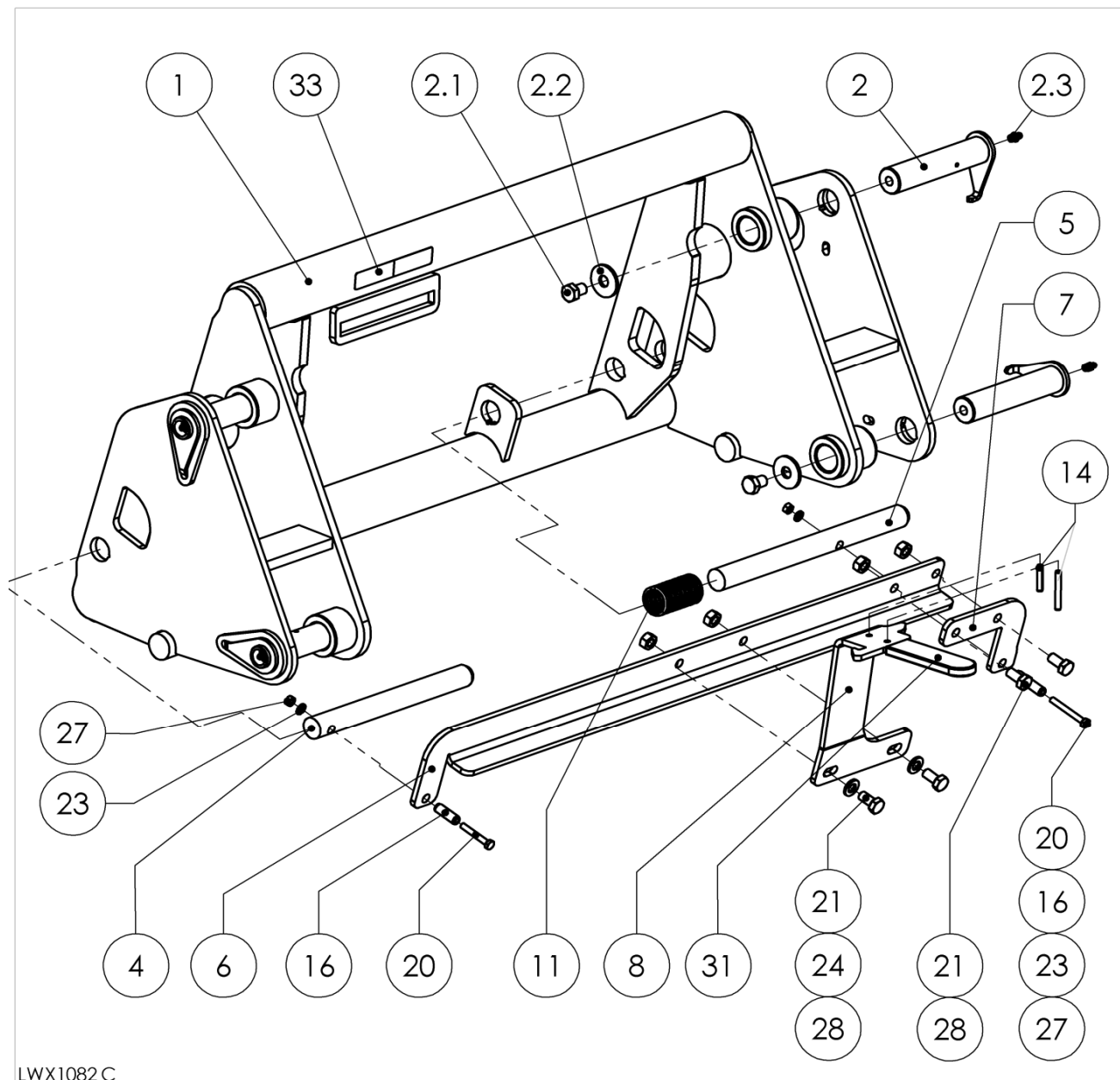

LWX1082 C

LWX 1082		Wechselrahmen SMS	Coupler SMS	Bâti à Changement SMS	STOLL FE	FE 650 P	FE 650 H	FE 750 P	FE 750 H	FE 850 P	FE 850 H	FE 950 P	FE 950 H
Pos.	Bestell-Nr.	Benennung	Description	Désignation	Zeichnungsnr.	SIZE/MASS							
1	3563120	Wechselrahmen gsw	Frame coupler	Bâti à Changement soudé	58.800-102-02-01		1	1	1	1	1	1	1
2	3563260	Bolzen gsw.	Bolt coupler	Boulon soudé	58.800-15		4	4	4	4	4	4	4
2.1	1404310	Sechskantschraube	Hex bolt	Vis	D 933	M12x16	4	4	4	4	4	4	4
2.2	0014070	Scheibe	Plain washer	Rondelle	D 9021	A13	4	4	4	4	4	4	4
2.3	0406590	Schmiernippel	Grease nipple	Graisser		AS8x1	4	4	4	4	4	4	4
4	3563130	Stecker kz	Pin	Axe	58.800-102-02-00.1		1	1	1	1	1	1	1
5	3563140	Stecker lg	Pin	Axe	58.800-102-02-00.2		1	1	1	1	1	1	1
6	3563150	Verriegelungsschiene	Llocking bar	Barre de verrouillage	58.800-102-02-00.3		1	1	1	1	1	1	1
7	3563160	Winkel	Angle	Angle	58.800-102-02-00.4		1	1	1	1	1	1	1
8	3563170	Verriegelungshebel	locking lever	Le levier de verrouillage	58.800-102-02-00.5		1	1	1	1	1	1	1
11	1418360	Druckfeder	Pressure spring	Ressort de pression	GUKU VD-288 Z-24	3X33X229	1	1	1	1	1	1	1
14	0063810	Spannstift	Spring-type straight pin	Goupille	ISO 8752	6 X 30 ZN	2	2	2	2	2	2	2
16	0453580	Spannstift	Spring-type straight pin	Goupille	ISO 8752	10 X 36 ZN	2	2	2	2	2	2	2
20	0491720	Sechskantschraube	Hex bolt	Vis	D 931	M 6X50 8.8 ZN	2	2	2	2	2	2	2
21	0011130	Sechskantschraube	Hex bolt	Vis	D 933	M10X25 8.8 ZN	4	4	4	4	4	4	4
23	0418390	Scheibe	Plain washer	Rondelle	D 9021	6,4 ST ZN-BLAU	2	2	2	2	2	2	2
24	0206850	Scheibe	Plain washer	Rondelle	D 126	11 ST ZN	2	2	2	2	2	2	2
27	0412570	Sicherungsmutter	Lock nut	Ecrou autofreiné	D 985 NICHTMET.KL.	NM 6 8ZN-BLAU	2	2	2	2	2	2	2
28	0011940	Sicherungsmutter	Lock nut	Ecrou autofreiné	D 985 NICHTMET.KL.	NM 10 8ZN	4	4	4	4	4	4	4
31	1427780	Handschutzhülle	Hand protection cap	Capuchon de protection à la main	MOSS RRWA91689-110	PVC schwarz	1	1	1	1	1	1	1
33	3574910	Aufkleber Verriegelung	Decal Locking	Autocollant Blocage	58.800-102-10-00.1		1	1	1	1	1	1	1

STOLL FE

DE Wechselrahmen
EURO/SMS

EN Coupler EURO/SMS

FR Bâti à Changement
EURO/SMS

FE 650 P/H
FE 750 P/H
FE 850 P/H
FE 950 P/H

FE 650 P/H
FE 750 P/H
FE 850 P/H
FE 950 P/H

FE 650 P/H
FE 750 P/H
FE 850 P/H
FE 950 P/H

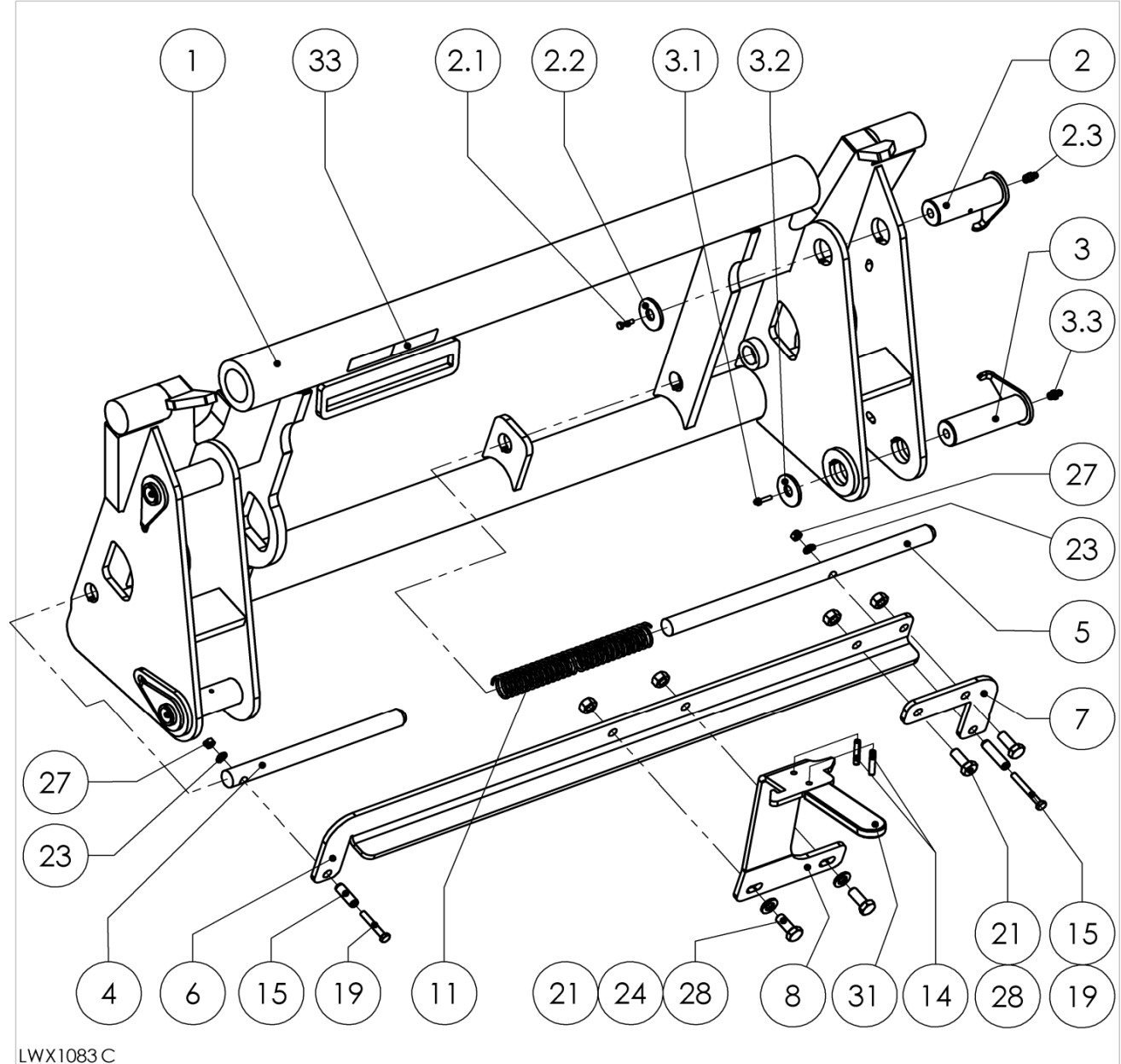

LWX1083 C

LWX 1083		Wechselrahmen EURO/SMS	Coupler EURO/SMS	Bâti à Changement EURO/SMS	STOLL FE	FE 650 P	FE 650 H	FE 750 P	FE 750 H	FE 850 P	FE 850 H	FE 950 P	FE 950 H
Pos.	Bestell-Nr.	Benennung	Description	Désignation	Zeichnungsnr.	SIZE/MASS							
1	3563240	Wechselrahmen gsw	Frame coupler	Bâti à Changement soudé	58.800-102-03-01		1	1	1	1	1	1	1
2	3501400	Bolzen gsw.	Bolt coupler	Boulon soudé	58.800-11		2	2	2	2	2	2	2
2.1	1404310	Sechskantschraube	Hex bolt	Vis	D 933	M12x16	2	2	2	2	2	2	2
2.2	0014070	Scheibe	Plain washer	Rondelle	D 9021	A13	2	2	2	2	2	2	2
2.3	0406590	Schmiernippel	Grease nipple	Graisser		AS8x1	2	2	2	2	2	2	2
3	3501450	Bolzen gsw.	Bolt coupler	Boulon soudé	58.800-13		2	2	2	2	2	2	2
3.1	1404310	Sechskantschraube	Hex bolt	Vis	D 933	M12x16	2	2	2	2	2	2	2
3.2	0014070	Scheibe	Plain washer	Rondelle	D 9021	A13	2	2	2	2	2	2	2
3.3	0406590	Schmiernippel	Grease nipple	Graisser		AS8x1	2	2	2	2	2	2	2
4	3563270	Stecker kz	Pin	Axe	58.800-102-03-00.1		1	1	1	1	1	1	1
5	3563280	Stecker lg	Pin	Axe	58.800-102-03-00.2		1	1	1	1	1	1	1
6	3563150	Verriegelungsschiene	Llocking bar	Barre de verrouillage	58.800-102-02-00.3		1	1	1	1	1	1	1
7	3563160	Winkel	Angle	Angle	58.800-102-02-00.4		1	1	1	1	1	1	1
8	3563170	Verriegelungshebel	locking lever	Le levier de verrouillage	58.800-102-02-00.5		1	1	1	1	1	1	1
11	3350970	Druckfeder	Pressure spring	Ressort de pression	58.420-21-00.1		2	2	2	2	2	2	2
14	0063810	Spannstift	Spring-type straight pin	Goupille	ISO 8752	6 X 30 ZN	2	2	2	2	2	2	2
15	0423990	Spannstift	Spring-type straight pin	Goupille	ISO 8752	10 X 30 ZN	2	2	2	2	2	2	2
19	0429010	Sechskantschraube	Hex bolt	Vis	D 931	M 6X 40 8.8 ZN	2	2	2	2	2	2	2
21	0011130	Sechskantschraube	Hex bolt	Vis	D 933	M10X 25 8.8 ZN	4	4	4	4	4	4	4
23	0418390	Scheibe	Plain washer	Rondelle	D 9021	6,4 ST ZN-BLAU	2	2	2	2	2	2	2
24	0206850	Scheibe	Plain washer	Rondelle	D 126	11 ST ZN	2	2	2	2	2	2	2
27	0412570	Sicherungsmutter	Lock nut	Ecrou autofreiné	D 985 NICHTMET.KL.	NM6 8ZN-BLAU	2	2	2	2	2	2	2
28	0011940	Sicherungsmutter	Lock nut	Ecrou autofreiné	D 985 NICHTMET.KL.	NM10 8 ZN	4	4	4	4	4	4	4
31	1427780	Handschutzkappe	Hand protection cap	Capuchon de protection à la main	MOSS RRWA91689-110	PVC schwarz	1	1	1	1	1	1	1
33	3574910	Aufkleber Verriegelung	Decal Locking	Autocollant Blocage	58.800-102-10-00.1		1	1	1	1	1	1	1

STOLL FE

DE Wechselrahmen
EURO-ZV

FE 650 P/H
FE 750 P/H
FE 850 P/H
FE 950 P/H

EN Coupler EURO-ZV

FE 650 P/H
FE 750 P/H
FE 850 P/H
FE 950 P/H

FR Bâti à Changement
EURO-ZV

FE 650 P/H
FE 750 P/H
FE 850 P/H
FE 950 P/H

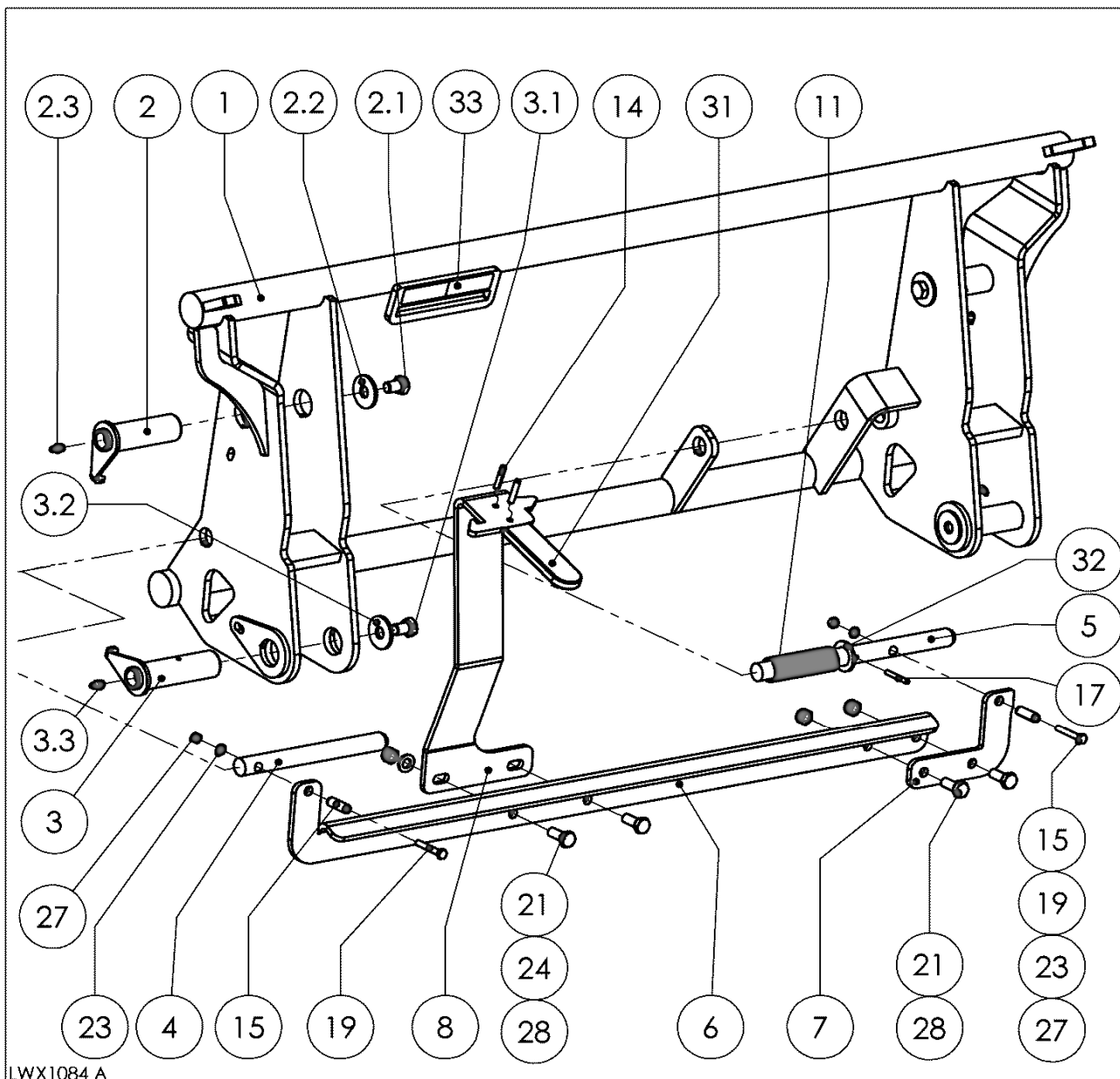

LWX1084 A

LWX 1084		Wechselrahmen EURO-ZV	Coupler EURO-ZV	Bâti à Changement EURO-ZV	STOLL FE	FE 650 P	FE 650 H	FE 750 P	FE 750 H	FE 850 P	FE 850 H	FE 950 P	FE 950 H
Pos.	Bestell-Nr.	Benennung	Description	Désignation	Zeichnungsnr.	SIZE/MASS							
1	3563390	Wechselrahmen gsw	Frame coupler	Bâti à Changement soudé	58.800-102-01-01		1	1	1	1	1	1	1
2	3501400	Bolzen gsw.	Bolt coupler	Boulon soudé	58.800-11		2	2	2	2	2	2	2
2.1	1404310	Sechskantschraube	Hex bolt	Vis	D 933	M12x16	2	2	2	2	2	2	2
2.2	0014070	Scheibe	Plain washer	Rondelle	D 9021	A13	2	2	2	2	2	2	2
2.3	0406590	Schmiernippel	Grease nipple	Graisser		AS8x1	2	2	2	2	2	2	2
3	3501450	Bolzen gsw.	Bolt coupler	Boulon soudé	58.800-13		2	2	2	2	2	2	2
3.1	1404310	Sechskantschraube	Hex bolt	Vis	D 933	M12x16	2	2	2	2	2	2	2
3.2	0014070	Scheibe	Plain washer	Rondelle	D 9021	A13	2	2	2	2	2	2	2
3.3	0406590	Schmiernippel	Grease nipple	Graisser		AS8x1	2	2	2	2	2	2	2
4	3563300	Stecker kz	Pin	Axe	58.800-102-01-00.1		1	1	1	1	1	1	1
5	3563310	Stecker lg	Pin	Axe	58.800-102-01-00.2		1	1	1	1	1	1	1
6	3563320	Verriegelungsschiene	Llocking bar	Barre de verrouillage	58.800-102-01-00.3		1	1	1	1	1	1	1
7	3563160	Winkel	Angle	Angle	58.800-102-02-00.4		1	1	1	1	1	1	1
8	3563330	Verriegelungshebel	locking lever	Le levier de verrouillage	58.800-102-01-00.5		1	1	1	1	1	1	1
11	3350970	Druckfeder	Pressure spring	Ressort de pression	58.420-21-00.1		1	1	1	1	1	1	1
14	0063810	Spannstift	Spring-type straight pin	Goupille	ISO 8752	6 X 30 ZN	2	2	2	2	2	2	2
15	0423990	Spannstift	Spring-type straight pin	Goupille	ISO 8752	10 X 30 ZN	2	2	2	2	2	2	2
17	0013090	Spannstift	Spring-type straight pin	Goupille	ISO 8752	5 X 36 ZN	1	1	1	1	1	1	1
19	0429010	Sechskantschraube	Hex bolt	Vis	D 931	M 6X 40 8.8 ZN	2	2	2	2	2	2	2
21	0011130	Sechskantschraube	Hex bolt	Vis	D 933	M10X 25 8.8 ZN	4	4	4	4	4	4	4
23	0418390	Scheibe	Plain washer	Rondelle	D 9021	6,4 ST ZN-BLAU	2	2	2	2	2	2	2
24	0206850	Scheibe	Plain washer	Rondelle	D 126	11 ST ZN	2	2	2	2	2	2	2
27	0412570	Sicherungsmutter	Lock nut	Ecrou autofreiné	D 985 NICHTMET.KL.	NM6 8ZN-BLAU	2	2	2	2	2	2	2
28	0011940	Sicherungsmutter	Lock nut	Ecrou autofreiné	D 985 NICHTMET.KL.	NM10 8 ZN	4	4	4	4	4	4	4
31	1427780	Handschutzkappe	Hand protection cap	Capuchon de protection à la main	MOSS RRWA91689-110	PVC schwarz	1	1	1	1	1	1	1
32	0006410	Scheibe	Plain washer	Rondelle	D 433	21 ST ZN_BLAU	1	1	1	1	1	1	1
33	3574910	Aufkleber Verriegelung	Decal Locking	Autocollant Blocage	58.800-102-10-00.1		1	1	1	1	1	1	1

STOLL FE

DE Hydraulik-
Ausrüstung

FE 650 P/H
FE 750 P/H

EN Hydraulik
Equipment

FE 650 P/H
FE 750 P/H

FR Equipement
Hydraulique

FE 650 P/H
FE 750 P/H

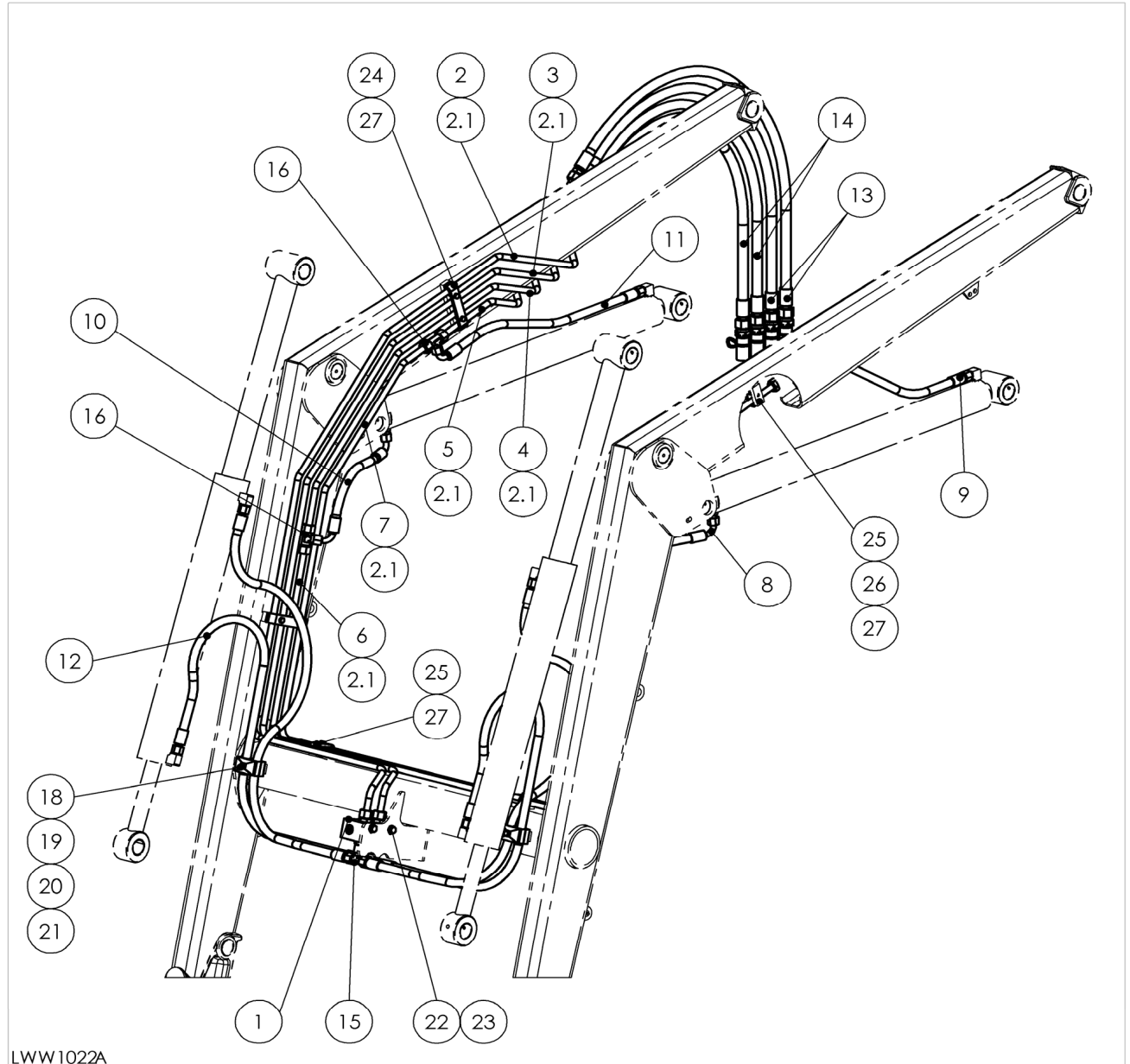

LWW1022A

	LWW 1022	Hydraulik-Ausrüstung	Hydraulik Equipment	Equipement Hydraulique	STOLL FE		FE 650 H	FE 650 P	FE 750 H	FE 750 P
Pos.	Bestell-Nr.	Benennung	Description	Désignation	Zeichnungsnr.	SIZE/MASS				
1	3501760	Ventil	Valve	Valve	58.800-19-20		1	1	1	1
2	3500230	Hydraulikrohr Schütten	Hydraulic pipe dump	Tuyau hydraulique benner	58.804-19-01		1	1		
2.1	1429340	Dichtung	Seal ring	Bague d'étanchéité		WALFORM 12 L	12	12	12	12
2	3500290	Hydraulikrohr Schütten	Hydraulic pipe dump	Tuyau hydraulique benner	58.800-19-01				1	1
3	3500240	Hydraulikrohr Schöpfen	Hydraulic pipe scoop	Tuyau hydraulique caver	58.804-19-02		1	1		
3	3500300	Hydraulikrohr Schöpfen	Hydraulic pipe scoop	Tuyau hydraulique caver	58.800-19-02				1	1
4	3500250	Hydraulikrohr Heben hi	Hydraulic pipe lift back	Tuyau hydraulique lever arrière	58.804-19-03		1	1		
4	3500310	Hydraulikrohr Heben hi	Hydraulic pipe lift back	Tuyau hydraulique lever arrière	58.800-19-03				1	1
5	3500260	Hydraulikrohr Senken hi	Hydraulic pipe down back	Tuyau hydraulique baisser arrière	58.804-19-04		1	1		
5	3500320	Hydraulikrohr Senken hi	Hydraulic pipe down back	Tuyau hydraulique baisser arrière	58.800-19-04				1	1
6	3500270	Hydraulikrohr Heben vo	Hydraulic pipe lift front	Tuyau hydraulique lever à l'avant	58.804-19-05		1	1		
6	3500330	Hydraulikrohr Heben vo	Hydraulic pipe lift front	Tuyau hydraulique lever à l'avant	58.800-19-05				1	1
7	3500280	Hydraulikrohr Senken vo	Hydraulic pipe down front	Tuyau hydraulique baisser à l'avant	58.804-19-06		1	1		
7	3500340	Hydraulikrohr Senken vo	Hydraulic pipe down front	Tuyau hydraulique baisser à l'avant	58.800-19-06				1	1
8	3502970	Schlauchleitung Heben li	Hose lift LH	Flexible lever gauche	1SN D M18x1,5 RKN90 - 08x 370		1	1	1	1
9	3503000	Schlauchleitung Senken li	Hose down LH	Flexible baisser gauche	1SN ND M18x1,5 08x 530		1	1	1	1
10	3503010	Schlauchleitung Heben re	Hose lift RH	Flexible lever droit	1SN RKN90 RKN90 - 08x 320 - 305Gr		1	1	1	1
11	3503050	Schlauchleitung Senken re	Hose down RH	Flexible baisser droit	1SN N RKN90 - 08x 620		1	1	1	1
12	3503060	Schlauchleitung Werkzeugzylinder	Hose Cylinder Bucket	Flexible Vérin d' outil	1SN NN 08x1150		4	4	4	4
13	3503090	Schlauchleitung Heben/Senken	Hose lift/down	Flexible lever/baisser	2SN N M22x1,5 D 10x1100		2	2	2	2
14	3503080	Schlauchleitung Schöpfen/Schütten	Hose scoop/dump	Flexible caver/benner	2SN N M22x1,5 D 10x1000		2	2	2	2
15	0423451	einstellbare T-Verschraubung	Adjustable branch Tee	Té orientable	WA ETSD 10 L A3L		2	2	2	2
16	1432060	T-Stutzen	Equal Tee	Union té	WA TS 12-12-10 L A3L		2	2	2	2
18	1429300	Rohrschelle	Pipe clip	Bride pour tuyaux	215\15		2	2	2	2
19	1429310	Deckplatte	Cover plate	Plaque supérieur	GD 2D		2	2	2	2
20	1426120	Sechskantschraube	Hex bolt	Vis	ISO 4017 - M6 x 40-C 8.8 ZN		2	2	2	2
21	0426680	Scheibe	Plain washer	Rondelle	Washer ISO 7089 - 6 ZN		2	2	2	2
22	0011080	Sechskantschraube	Hex bolt	Vis	ISO 4017 - M8 x 16-C 8.8 ZN		2	2	2	2
23	0426650	Scheibe	Plain washer	Rondelle	Washer ISO 7089 - 8 ZN		2	2	2	2
24	0513230	Halter	Support	Support	58.10-00.3		2	2	2	2
25	1329440	Halter	Support	Support	58.33-00.4		4	4	4	4
26	1329450	Rohr	Pipe	Tuyau	58.33-00.5		1	1	1	1
27	0011070	Sechskantschraube	Hex bolt	Vis	ISO 4017 - M6 x 25- 8.8 ZN		8	8	8	8

STOLL FE

DE Hydraulik-
Ausrüstung

EN Hydraulik
Equipment

FR Equipement
Hydraulique

FE 850 P/H
FE 950 P/H

FE 850 P/H
FE 950 P/H

FE 850 P/H
FE 950 P/H

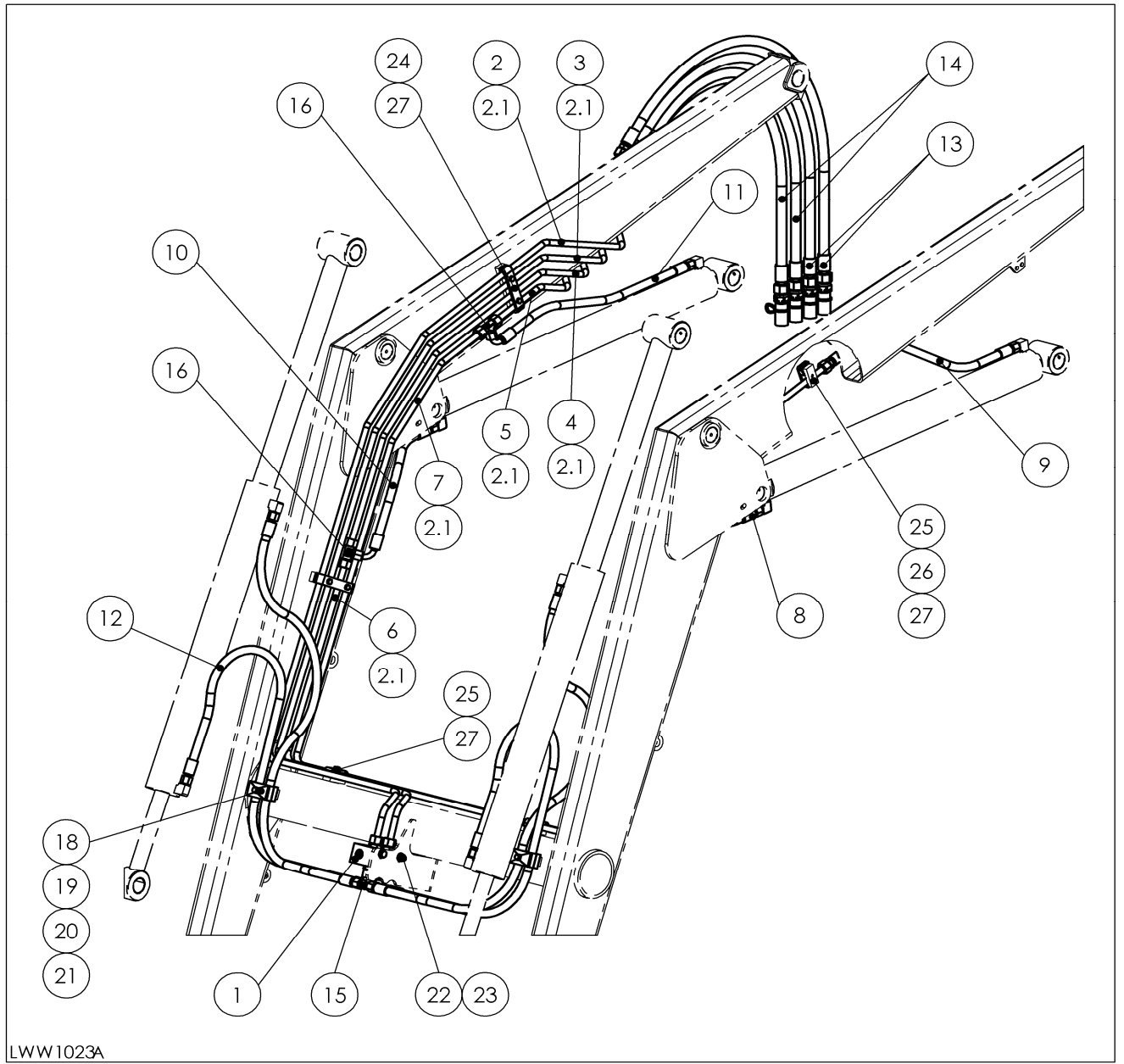

LWW1023A

LWW 1023		Hydraulik-Ausrüstung	Hydraulik Equipment	Equipement Hydraulique	STOLL FE	FE 850 H	FE 850 P	FE 950 H	FE 950 P
Pos.	Bestell-Nr.	Benennung	Description	Désignation	Zeichnungsnr.	SIZE/MASS			
1	3501760	Ventil	Valve	Valve	58.800-19-20		1	1	1
2	3500350	Hydraulikrohr Schütten	Hydraulic pipe dump	Tuyau hydraulique benner	58.810-19-01		1	1	
2	3500410	Hydraulikrohr Schütten	Hydraulic pipe dump	Tuyau hydraulique benner	58.820-19-01			1	1
2.1	1429340	Dichtung	Seal ring	Bague d'etanchéité		WALFORM 12 L	12	12	12
3	3500360	Hydraulikrohr Schöpfen	Hydraulic pipe scoop	Tuyau hydraulique caver	58.810-19-02		1	1	
3	3500420	Hydraulikrohr Schöpfen	Hydraulic pipe scoop	Tuyau hydraulique caver	58.820-19-02			1	1
4	3500370	Hydraulikrohr Heben hi	Hydraulic pipe lift back	Tuyau hydraulique lever arrière	58.810-19-03		1	1	
4	3500430	Hydraulikrohr Heben hi	Hydraulic pipe lift back	Tuyau hydraulique lever arrière	58.820-19-03			1	1
5	3500380	Hydraulikrohr Senken hi	Hydraulic pipe down back	Tuyau hydraulique baisser arrière	58.810-19-04		1	1	
5	3500440	Hydraulikrohr Senken hi	Hydraulic pipe down back	Tuyau hydraulique baisser arrière	58.820-19-04			1	1
6	3500390	Hydraulikrohr Heben vo	Hydraulic pipe lift front	Tuyau hydraulique lever à l'avant	58.810-19-05		1	1	
6	3500450	Hydraulikrohr Heben vo	Hydraulic pipe lift front	Tuyau hydraulique lever à l'avant	58.820-19-05			1	1
7	3500400	Hydraulikrohr Senken vo	Hydraulic pipe down front	Tuyau hydraulique baisser à l'avant	58.810-19-06		1	1	
7	3500460	Hydraulikrohr Senken vo	Hydraulic pipe down front	Tuyau hydraulique baisser à l'avant	58.820-19-06			1	1
8	3502980	Schlauchleitung Heben li	Hose lift LH	Flexible lever gauche	1SN ND M18x1,5 08x 420		1	1	1
9	3503000	Schlauchleitung Senken li	Hose down LH	Flexible baisser gauche	1SN ND M18x1,5 08x 530		1	1	1
10	3503040	Schlauchleitung Heben re	Hose lift RH	Flexible lever droit	1SN N RKN90 - 08x 400		1	1	1
11	3503050	Schlauchleitung Senken re	Hose down RH	Flexible baisser droit	1SN N RKN90 - 08x 620		1	1	1
12	3503060	Schlauchleitung Werkzeugzylinder	Hose Cylinder Bucket	Flexible Vérin d' outil	1SN NN 08x1150		4	4	4
13	3503090	Schlauchleitung Heben/Senken	Hose lift/down	Flexible lever/baisser	2SN N M22x1,5 D 10x1100		2	2	2
14	3503080	Schlauchleitung Schöpfen/Schütten	Hose scoop/dump	Flexible caver/benner	2SN N M22x1,5 D 10x1000		2	2	2
15	0423451	einstellbare T-Verschraubung	Adjustable branch Tee	Té orientable	WA ETSD 10 L A3L		2	2	2
16	1432060	T-Stutzen	Equal Tee	Union té	WA TS 12-12-10 L A3L		2	2	2
18	1429300	Rohrschelle	Pipe clip	Bride pour tuyaux	215\15		2	2	2
19	1429310	Deckplatte	Cover plate	Plaque supérieur	GD 2D		2	2	2
20	1426120	Sechskantschraube	Hex bolt	Vis	ISO 4017 - M6 x 40-C 8.8 ZN		2	2	2
21	0426680	Scheibe	Plain washer	Rondelle	Washer ISO 7089 - 6 ZN		2	2	2
22	0011080	Sechskantschraube	Hex bolt	Vis	ISO 4017 - M8 x 16-C 8.8 ZN		2	2	2
23	0426650	Scheibe	Plain washer	Rondelle	Washer ISO 7089 - 8 ZN		2	2	2
24	0513230	Halter	Support	Support	58.10-00.3		2	2	2
25	1329440	Halter	Support	Support	58.33-00.4		4	4	4
26	1329450	Rohr	Pipe	Tuyau	58.33-00.5		1	1	1
27	0011070	Sechskantschraube	Hex bolt	Vis	ISO 4017 - M6 x 25- 8.8 ZN		8	8	8

STOLL FE

DE Hebenzylinder P/H

EN Lifting cylinder P/H

FR Vérin de levage P/H

FE 650 P/H
FE 750 P/H
FE 850 P/H
FE 950 P/H

FE 650 P/H
FE 750 P/H
FE 850 P/H
FE 950 P/H

FE 650 P/H
FE 750 P/H
FE 850 P/H
FE 950 P/H

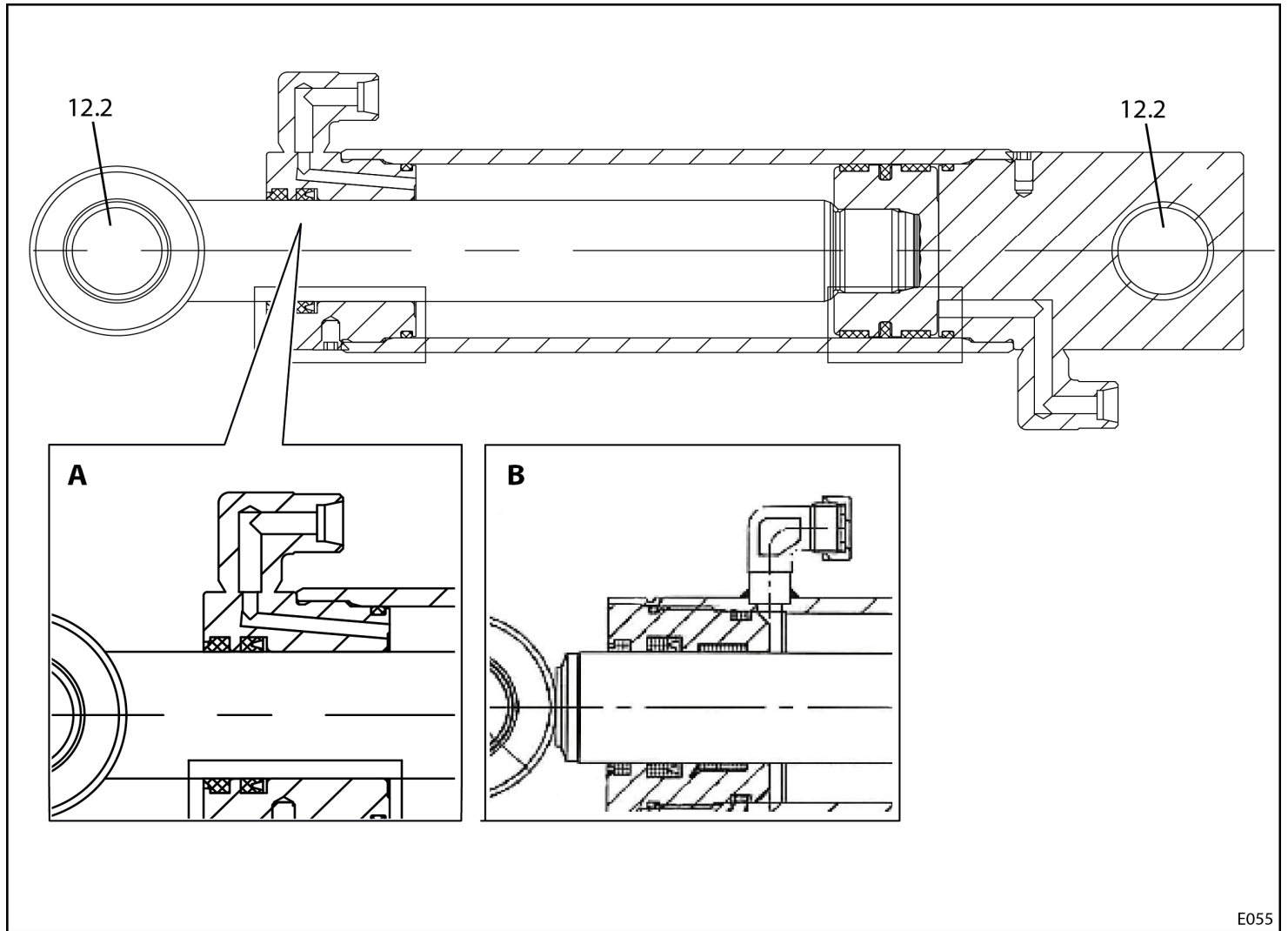

E055

	E055	Hebenzylinder P/H	Lifting cylinder P/H	Vérin de levage P/H	STOLL FE		FE 650 P	FE 650 H	FE 750 P	FE 750 H	FE 850 P	FE 850 H	FE 950 P	FE 950 H
Pos.	Bestell-Nr.	Benennung	Description	Désignation	Zeichnungsnr.	SIZE/MASS								
12A	3490630	Hebenzylinder	Cylinder Beam	Vérin de levage	58.02-170	50/30/760/605	2	2						
12.1A	3503190	Dichtsatz	Seal kit	Jeu de joint	58.02-170-01	50/30	2	2						
12.2	0481980	Verbundstoffbuchse	Bush	Douille		IHG PM 3030 DX	8	8						
12A	3490670	Hebenzylinder	Cylinder Beam	Vérin de levage	58.02-171	55/35/850/640			2	2				
12.1A	3503200	Dichtsatz	Seal kit	Jeu de joint	58.02-171-01	55/35			2	2				
12.2	0481980	Verbundstoffbuchse	Bush	Douille		IHG PM 3030 DX			8	8				
12A	3490680	Hebenzylinder	Cylinder Beam	Vérin de levage	58.02-172	60/35/850/640					2	2		
12B	3490682	Hebenzylinder	Cylinder Beam	Vérin de levage	58.02-172 B	60/35/850/640					2	2		
12.1A	3479850	Dichtsatz	Seal kit	Jeu de joint	58.02-152-01						2	2		
12.1B	3576550	Dichtsatz	Seal kit	Jeu de joint	58.02-172-01 B						2	2		
12.2	0481980	Verbundstoffbuchse	Bush	Douille		IHG PM 3030 DX					8	8		
12A	3490690	Hebenzylinder	Cylinder Beam	Vérin de levage	58.02-173	65/35/850/640							2	2
12.1A	3479870	Dichtsatz	Seal kit	Jeu de joint	58.02-154-01	65/35							2	2
12.2	0481980	Verbundstoffbuchse	Bush	Douille		IHG PM 3030 DX							8	8

STOLL FE

DE Werkzeugzylinder P

FE 650 P
FE 750 P
FE 850 P
FE 950 P

EN Tool actuating cylinder P

FE 650 P
FE 750 P
FE 850 P
FE 950 P

FR Vérin de outil P

FE 650 P
FE 750 P
FE 850 P
FE 950 P

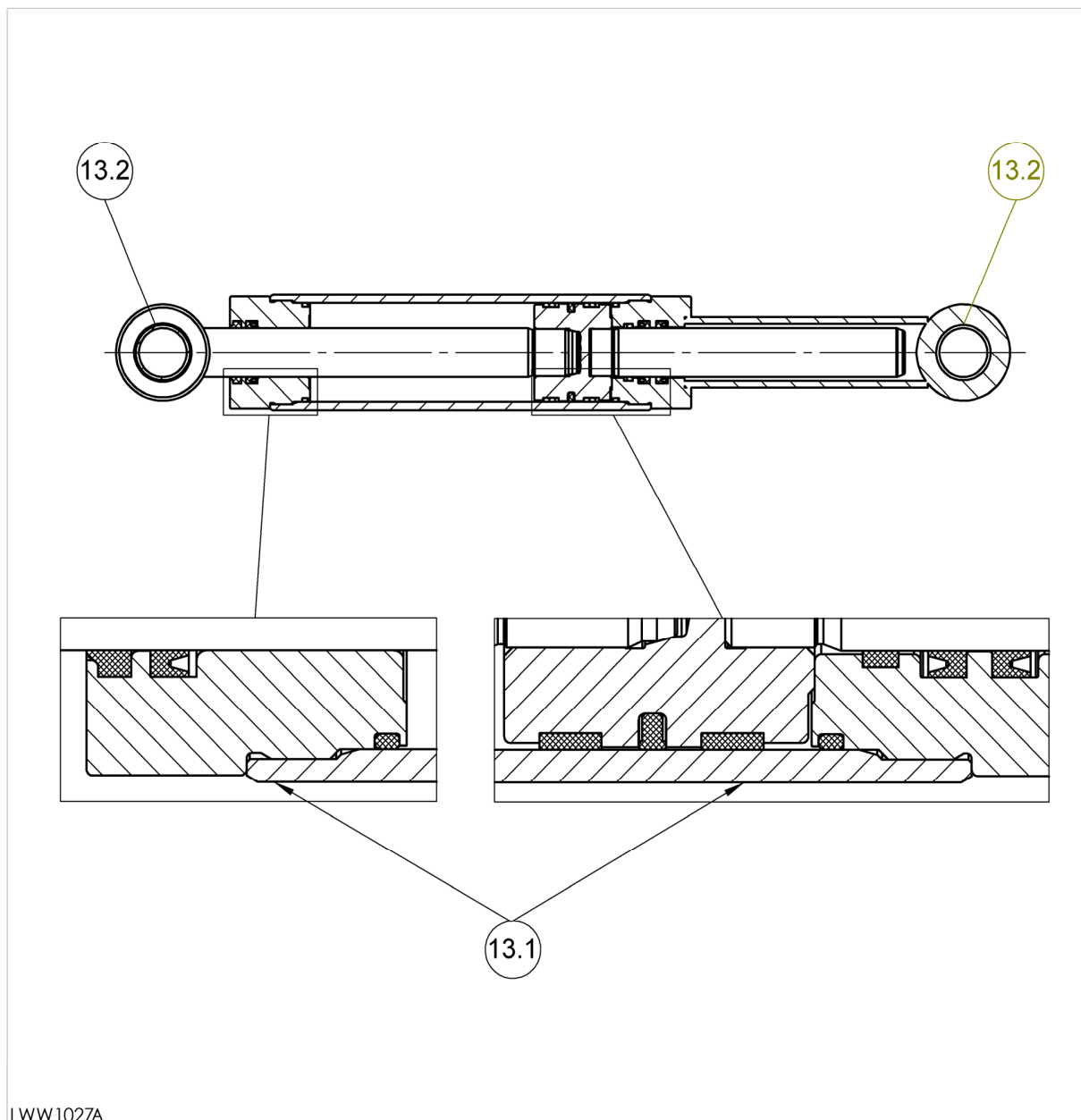

LWW1027A

	LWW 1027	Werkzeugzylinder P	Tool actuating cylinder P	Vérin de outil P	STOLL FE		FE 650 P	FE 750 P	FE 850 P	FE 950 P
Pos.	Bestell-Nr.	Benennung	Description	Désignation	Zeichnungsnr.	SIZE/MASS				
13	3490710	Werkzeugzylinder	Cylinder Bucket	Vérin d' outil	58.02-180	55/30/1030/405	2			
13.1	3503210	Dichtsatz	Seal kit	Jeu de joint	58.02-180-01	55/35	2			
13.2	0481980	Verbundstoffbuchse	Bush	Douille		IHG PM 3030 DX	4			
13.3	0482230	Verbundstoffbuchse	Bush	Douille		IHG PM 3040 DX	2			
13	3490720	Werkzeugzylinder	Cylinder Bucket	Vérin d' outil	58.02-181	60/30/1100/440		2		
13.1	3503220	Dichtsatz	Seal kit	Jeu de joint	58.02-181-01	60/30		2		
13.2	0481980	Verbundstoffbuchse	Bush	Douille		IHG PM 3030 DX		4		
13.3	0482230	Verbundstoffbuchse	Bush	Douille		IHG PM 3040 DX		2		
13	3490730	Werkzeugzylinder	Cylinder Bucket	Vérin d' outil	58.02-182	60/30/1230/500				2
13.1	3503220	Dichtsatz	Seal kit	Jeu de joint	58.02-181-01	60/30				2
13.2	0481980	Verbundstoffbuchse	Bush	Douille		IHG PM 3030 DX				4
13.3	0482230	Verbundstoffbuchse	Bush	Douille		IHG PM 3040 DX				2
13	3490700	Werkzeugzylinder	Cylinder Bucket	Vérin d' outil	58.02-183	65/35/1310/540				2
13.1	3503230	Dichtsatz	Seal kit	Jeu de joint	58.02-183-01	65/35				2
13.2	0481980	Verbundstoffbuchse	Bush	Douille		IHG PM 3030 DX				4
13.3	0482230	Verbundstoffbuchse	Bush	Douille		IHG PM 3040 DX				2

STOLL FE

- DE Werkzeugzylinder H
 - EN Tool actuating cylinder H
 - FR Vérin de outil H
- FE 650 H
FE 750 H
FE 850 H
FE 950 H
- FE 650 H
FE 750 H
FE 850 H
FE 950 H
- FE 650 H
FE 750 H
FE 850 H
FE 950 H

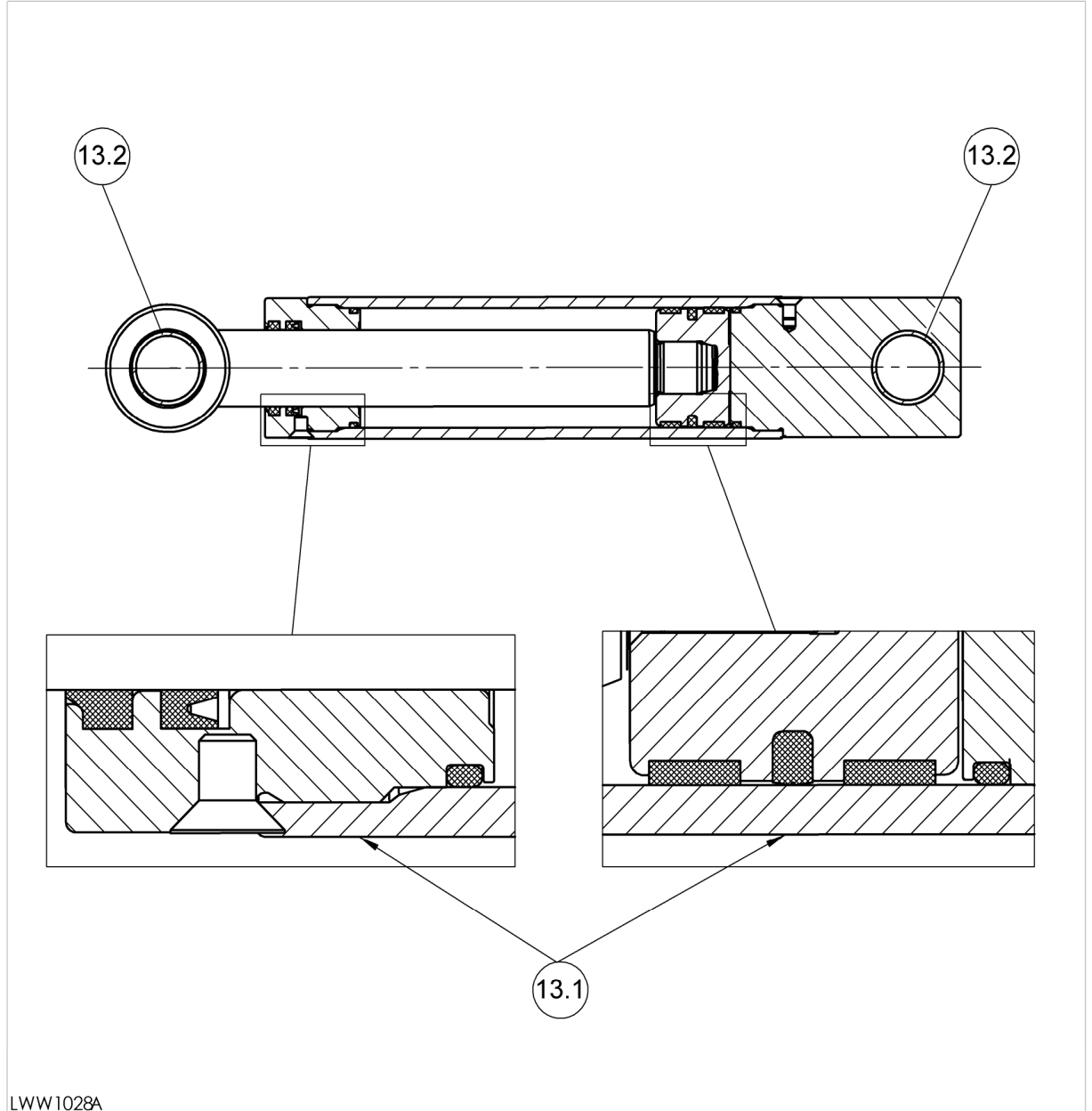

LWW 1028A

	LWW 1028	Werkzeugzylinder H	Tool actuating cylinder H	Vérin de outil H	STOLL FE		FE 650 H	FE 750 H	FE 850 H	FE 950 H
Pos.	Bestell-Nr.	Benennung	Description	Désignation	Zeichnungsnr.	SIZE/MASS				
13	3490740	Werkzeugzylinder	Cylinder Bucket	Vérin d' outil	58.02-190	55/35/850/640	2	2		
13.1	3503200	Dichtsatz	Seal kit	Jeu de joint	58.02-171-01	55/35	2	2		
13.2	0481980	Verbundstoffbuchse	Bush	Douille		IHG PM 3030 DX	4	4		
13.3	0482230	Verbundstoffbuchse	Bush	Douille		IHG PM 3040 DX	2	2		
13	3490750	Werkzeugzylinder	Cylinder Bucket	Vérin d' outil	58.02-192	60/35/850/640			2	2
13.1	3479850	Dichtsatz	Seal kit	Jeu de joint	58.02-152-01	60/35			2	2
13.2	0481980	Verbundstoffbuchse	Bush	Douille		IHG PM 3030 DX			4	4
13.3	0482230	Verbundstoffbuchse	Bush	Douille		IHG PM 3040 DX			2	2

STOLL FE

DE Steckkupplungen
3/8"

FE 650 P/H
FE 750 P/H
FE 850 P/H
FE 950 P/H

EN Connexion
hydraulique 3/8"

FE 650 P/H
FE 750 P/H
FE 850 P/H
FE 950 P/H

FR Connexion
hydraulique 3/8"

FE 650 P/H
FE 750 P/H
FE 850 P/H
FE 950 P/H

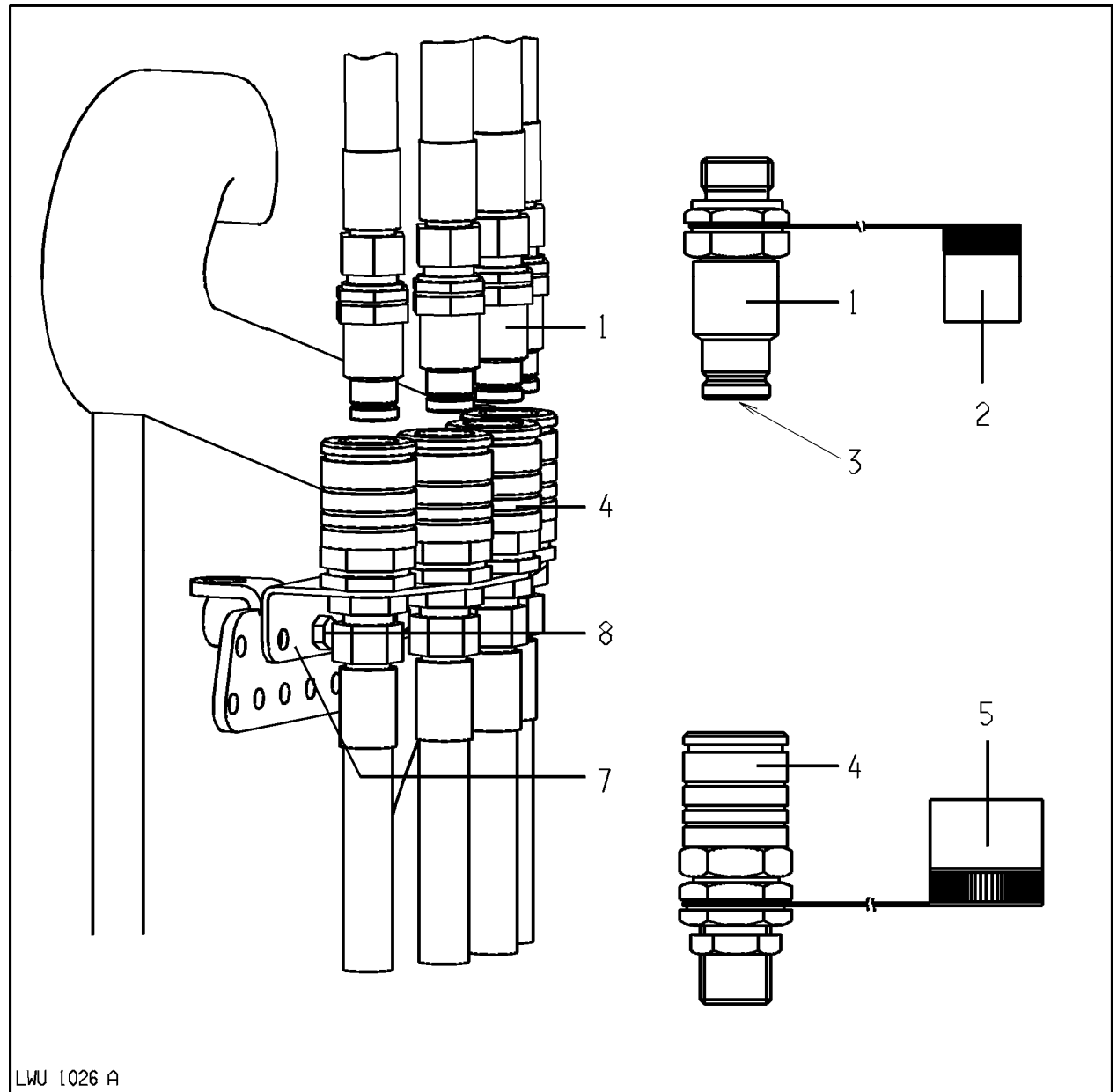

LWU 1026		Steckkupplungen 3/8"	Plug in coupling 3/8"	Connexion hydraulique 3/8"	STOLL FE	FE 650 P	FE 650 H	FE 750 P	FE 750 H	FE 850 P	FE 850 H	FE 950 P	FE 950 H
Pos.	Bestell-Nr.	Benennung	Description	Désignation	Zeichnungsnr. SIZE/MASS								
1	0477610	Kupplungsstecker	Coupler plug	Connexion Mâle	FFN 38-2/2215M	4	4	4	4	4	4	4	4
2	1408500	Staubkappe-Stecker blau	Dust cap-plug blue	Capuchon contre la poussière-fiche bleu	TFF2FN 38 B	1	1	1	1	1	1	1	1
2	1408520	Staubkappe-Stecker grün	Dust cap-plug green	Capuchon contre la poussière-fiche vert	TFF2FN 38 V	1	1	1	1	1	1	1	1
2	1408540	Staubkappe-Stecker rot	Dust cap-plug red	Capuchon contre la poussière-fiche rouge	TFF2FN 38 R	1	1	1	1	1	1	1	1
2	1408560	Staubkappe-Stecker gelb	Dust cap-plug yellow	Capuchon contre la poussière-fiche jaune	TFF2FN 38 G	1	1	1	1	1	1	1	1
3	1420520	Dichtung	Sealing	Joint	3/8 FASTER	4	4	4	4	4	4	4	4
4	0480810	Kupplungsmuffe-Schott	Coupling box	Connexion femelle	FFN 38-7/2215F	4	4	4	4	4	4	4	4
5	1408490	Staubkappe-Muffe blau	Dust cap-plug blue	Capuchon contre la poussière-manchon bleu	TMF2FN 38 B	1	1	1	1	1	1	1	1
5	1408510	Staubkappe-Muffe grün	Dust cap-plug green	Capuchon contre la poussière-manchon vert	TMF2FN38 V	1	1	1	1	1	1	1	1
5	1408530	Staubkappe-Muffe rot	Dust cap-plug red	Capuchon contre la poussière-manchon rouge	TMF2FN 38 R	1	1	1	1	1	1	1	1
5	1408550	Staubkappe-Muffe gelb	Dust cap-plug yellow	Capuchon contre la poussière-manchon jaune	TMF2FN 38 G	1	1	1	1	1	1	1	1
7	3332960	Halter	Support	Support	58.420-04-00.1	1	1	1	1	1	1	1	1
8	0011090	Sechskantschraube	Screw	Vis	M 8x20	2	2	2	2	2	2	2	2
8	0011630	Sechskantmutter	Nut	Ecrou	M 8	2	2	2	2	2	2	2	2
8	0452140	Sicherheitsring	Circlip	Circlip	8	2	2	2	2	2	2	2	2

STOLL FE

DE Hydro-Fix

FE 650 P/H
FE 750 P/H
FE 850 P/H
FE 950 P/H

EN Hydro-Fix

FE 650 P/H
FE 750 P/H
FE 850 P/H
FE 950 P/H

FR Hydro-Fix

FE 650 P/H
FE 750 P/H
FE 850 P/H
FE 950 P/H

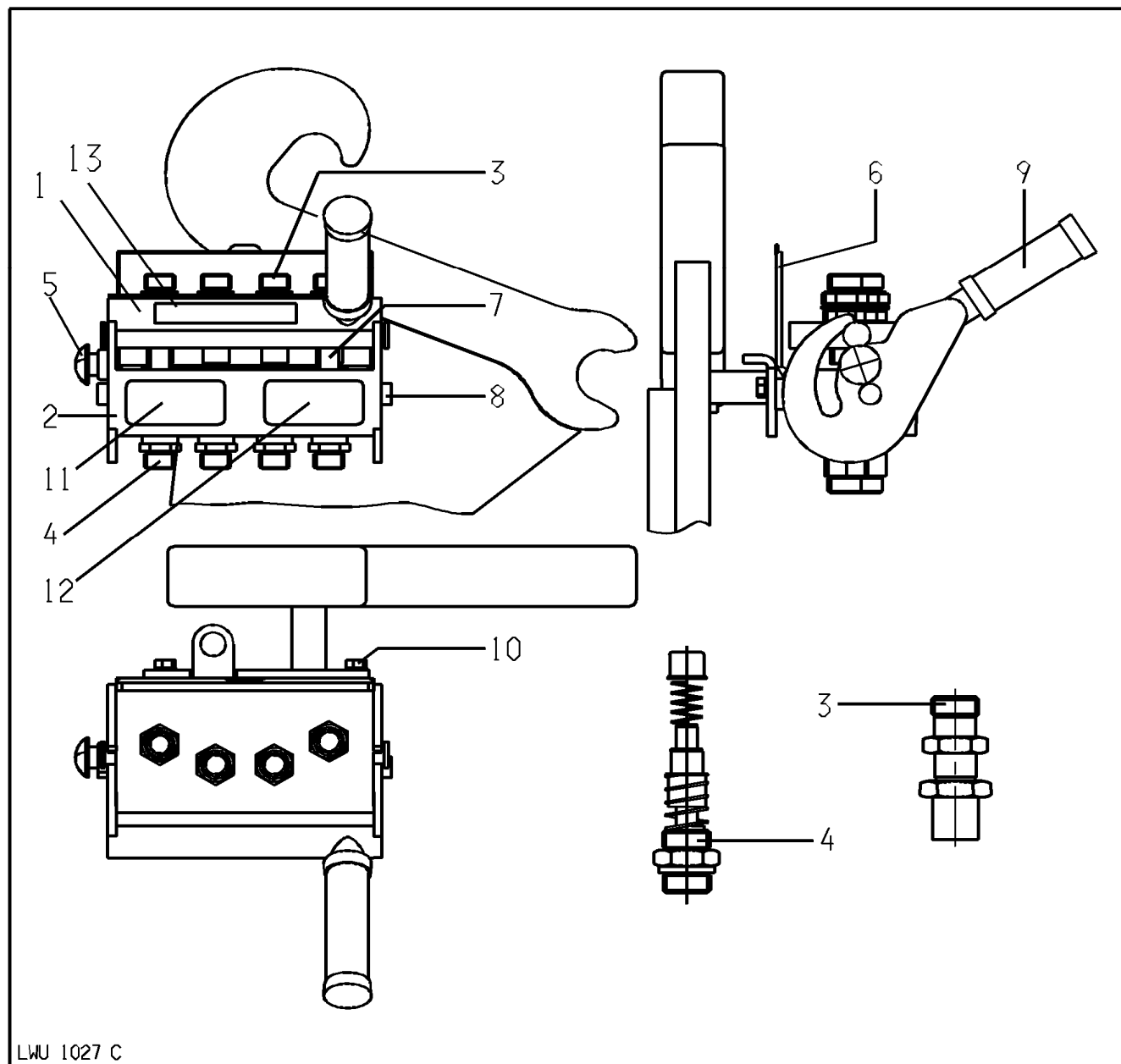

LWU 1027 C

	LWU1027	Hydro-Fix	Hydro-Fix	Hydro-Fix	STOLL FE		FE 650 P	FE 650 H	FE 750 P	FE 750 H	FE 850 P	FE 850 H	FE 950 P	FE 950 H
Pos.	Bestell-Nr.	Benennung	Description	Désignation	Zeichnungsnr.	SIZE/MASS								
-	0481600	Hydro-Fix DW	Hydro-Fix d.a.	Hydro-Fix		PS 06-4-2/2215	1	1	1	1	1	1	1	1
1	0481880	Hydro-Fix Oberenteil kpl (Teller)	Hydro-Fix upper part cpl.	Hydro-Fix partie haute cpl.		PS 06-4-2/2215 M	1	1	1	1	1	1	1	1
2	0481870	Hydro-Fix Unterteil kpl (Muffen)	Hydro-Fix lower part cpl.	Hydro-Fix partie Basse cpl.		PS 06-4-2/2215 F	1	1	1	1	1	1	1	1
2.1	1430190	Hydro-Fix Unterteil ohne Muffen	Hydro-Fix lower part	Hydro-Fix partie Basse sans les raccords		KIT PS 06 F	1	1	1	1	1	1	1	1
3	0481820	Stecker	Plug	Prise mâle			4	4	4	4	4	4	4	4
3.1	1420520	Dichtung kpl.	Sealing cpl.	Joint cpl.			4	4	4	4	4	4	4	4
4	0493660	Muffe	Socket	Prise femelle			4	4	4	4	4	4	4	4
5	1418430	Sicherheitverriegelung	Safety Locking	Verrouillage de sécurité		Kit SP 5	1	1	1	1	1	1	1	1
6	0481910	Deckel	Cover	Chapeau			1	1	1	1	1	1	1	1
7	0494680	Führungsbolzen mit Mutter	Bolt with nut	Boulon avec écrou			2	2	2	2	2	2	2	2
8	0494700	Schraube	Screw	Vis		Kit VP 4	2	2	2	2	2	2	2	2
9	0494720	Hebel	Lever	Levier		LP 6	1	1	1	1	1	1	1	1
10	0011090	Schskantschraube	Screw	Vis		M 8x20	2	2	2	2	2	2	2	2
10.1	0452140	Sicherheitsring	Safety ring	Bague de securité		8	2	2	2	2	2	2	2	2
11	3430500	Aufkleber Hydro-Fix Bild	Decal "Hydrofix picture"	Autocollant "Hydrofix image"		Fast ET011	1	1	1	1	1	1	1	1
12	3430510	Aufkleber Hydro-Fix Text	Decal "Hydrofix text"	Autocollant "Hydrofix texte"		Fast ET007	1	1	1	1	1	1	1	1
13	2403530	Aufkleber STOLL-Hydrofix	Decal "STOLL-Hydrofix"	Autocollant "STOLL-Hydrofix"		55.00-00.74	1	1	1	1	1	1	1	1

STOLL FE

Stecker / Plug / Prise male

Muffe / Socket / Prise femelle

- | | |
|-------------------------------|------------|
| | FE 650 P/H |
| | FE 750 P/H |
| DE Dichtsatz für Hydro-Fix | FE 850 P/H |
| | FE 950 P/H |
| | FE 650 P/H |
| EN Seal kit for Hydro-Fix | FE 750 P/H |
| | FE 850 P/H |
| | FE 950 P/H |
| | FE 650 P/H |
| FR Jeu de joints de Hydro-Fix | FE 750 P/H |
| | FE 850 P/H |
| | FE 950 P/H |

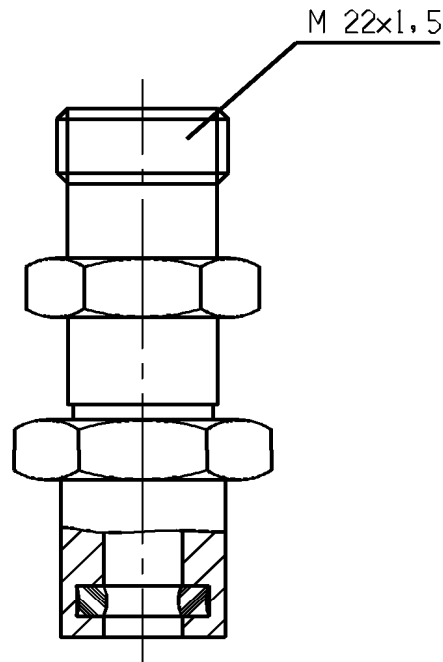

Dichtung
Sealing
Joint = 142 05 20

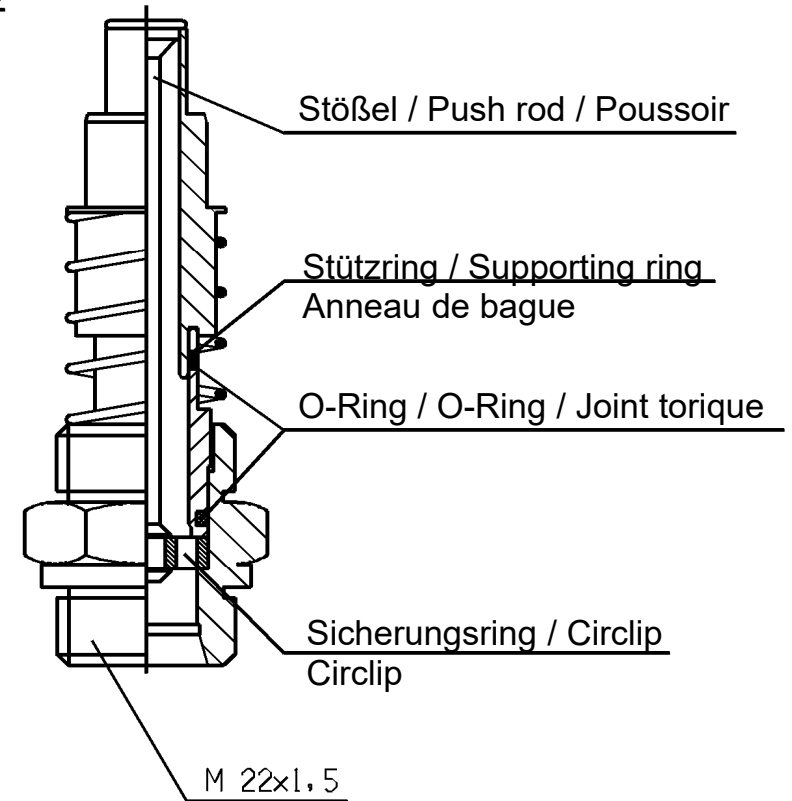

LWU 1028 B

Wegeventile Übersicht		Control valves, summary			Valves de commande, vue d'ensemble			Ecoline FE
Verwendung Employment Emploi	Ventilart Kind of valve Facon de valve	Grundventil Basic valve Valve de base			Komplettventil Valve cpl. Valve cpl.			Anschlußgröße
		Walvoil-Nr.	Bestell-Nr Reference No. No.de référence	Nimco-Nr.	Bestell-Nr Reference No. No.de référence	Zeichn-Nr. Drawing No. de dessin	Bestell-Nr Reference No. No.de référence	
opened hydraulik	dw/dw* da/da* de/de*	SDM 143/2- P	0 47 93 12	2S-4550	0 47 93 11	56.00-14 56.00-39	2 35 95 20 2 47 60 10	NW 12 NW 16
load sensing	dw/dw* da/da* de/de*	DLM 142/2- AP	0 47 92 92	2S-4570	0 47 92 91	56.00-16 56.00-49	2 35 95 40 3 32 84 50	NW 12 NW 16
closed hydraulik J.Deere 30, 40, 50 - Reihe	dw/dw* da/da* de/de*	---	---	2S-4550 **	0 47 93 11 **	56.00-156-01	3 53 30 60 **	NW 12
45 l/min opened hydraulik	dw/dw* da/da* de/de*	SDM 102/2	1 43 08 30	---	---	56.00-80	3 47 82 00	NW 12
<p>* doppelwirkendes Ventil kann auf einfachwirkend umgebaut werden/ (siehe Umbauanleitung 56.00-17-00.1/ 2466610) * double acting valve can to be modified to single acting / (see modification instruction 56.00-17-00.1/ 2466610) * il faut que le valve a double effet sera modifier en simple effet / (voir instructions de modification 56.00-17-00.1/ 2466610) ** Druckbegrenzungsventil komplett schließen (zudrehen) und Patrone mit VS 1/2 "0424360 verschließen. ** shutt off the airbrake valve completely and close the cartridge with screw 1/2" 0424360 ** fermer cpl. la valve du freinage pneumatique et bloquer la cartouche avec vis 1/2" 0424360</p>								

STOLL FE

DE Ventil

FE 650 P/H
FE 750 P/H
FE 850 P/H
FE 950 P/H

EN Valve

FE 650 P/H
FE 750 P/H
FE 850 P/H
FE 950 P/H

FR Valve

FE 650 P/H
FE 750 P/H
FE 850 P/H
FE 950 P/H

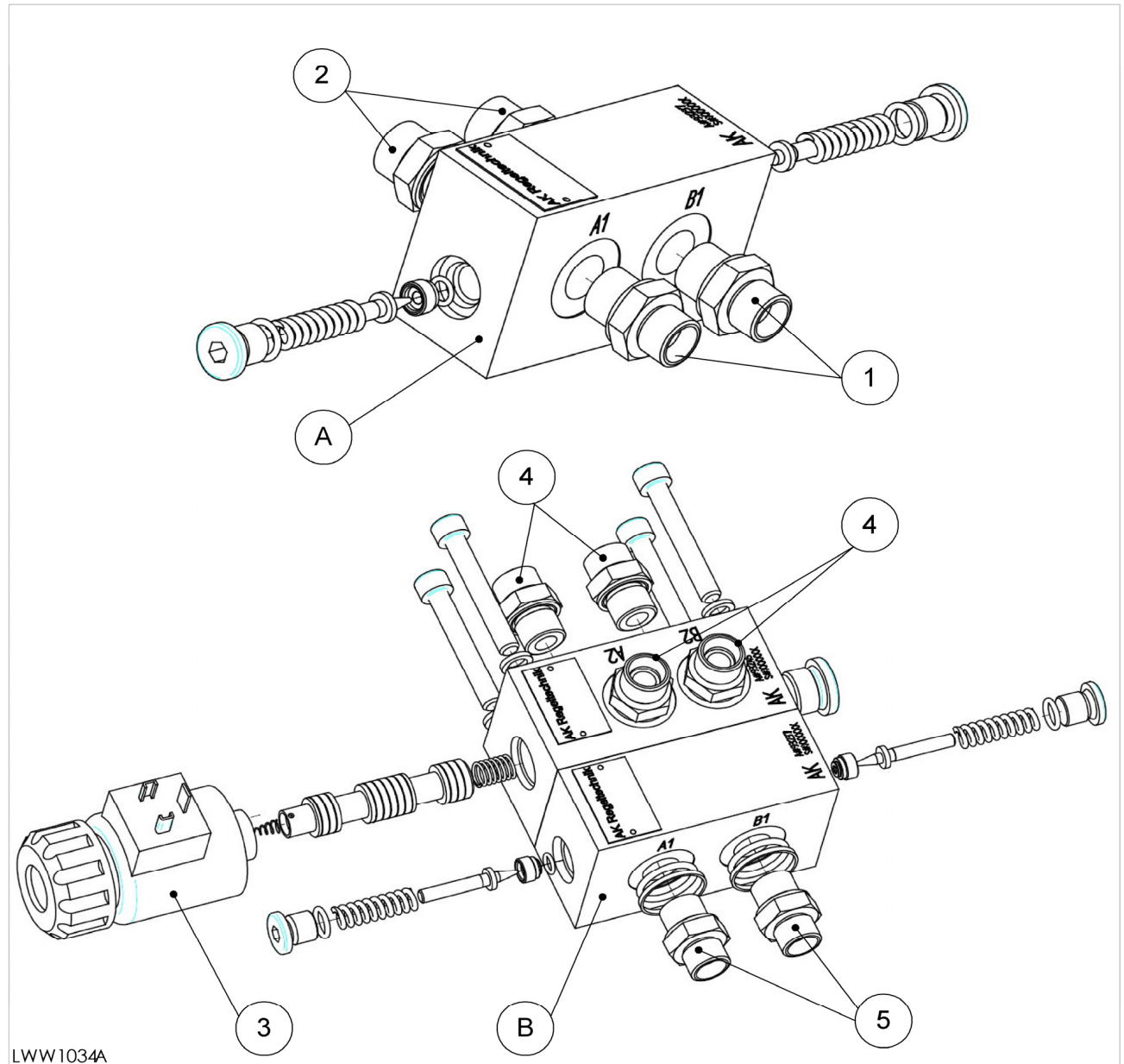

							FE 650 P	FE 650 H	FE 750 P	FE 750 H	FE 850 P	FE 850 H	FE 950 P	FE 950 H
Pos.	Bestell-Nr.	Benennung	Description	Désignation	Zeichnungsnr.	SIZE/MASS								
	LWW1034	Ventil	Valve	Valve	STOLL FE									
A	3501760	Ventil	Valve	Valve			1	1	1	1	1	1	1	1
1	0427741	Einschraubstutzen	Male stud coupling	Union simple mâle	WA GES 12LR A3L		2	2	2	2	2	2	2	2
2	0499500	Einschraubstutzen	Male stud coupling	Union simple mâle	WA GES 10LR 3/8		2	2	2	2	2	2	2	2
B	3501770	Ventil	Valve	Valve			1	1	1	1	1	1	1	1
3	3521780	Schaltmagnet	Switching magnet	Bobine magnétique	AK-REGELT-NR.80118		1	1	1	1	1	1	1	1
4	0427741	Einschraubstutzen	Male stud coupling	Union simple mâle	WA GES 12LR A3L		4	4	4	4	4	4	4	4
5	0499500	Einschraubstutzen	Male stud coupling	Union simple mâle	WA GES 10LR 3/8 A3L		2	2	2	2	2	2	2	2

STOLL FE

DE Dichtsatz für
Wegeventil Nimco

FE 650 P/H
FE 750 P/H
FE 850 P/H
FE 950 P/H

EN Seal kit for control
valve Nimco

FE 650 P/H
FE 750 P/H
FE 850 P/H
FE 950 P/H

FR Jeu de joints pour bloc
de commande Nimco

FE 650 P/H
FE 750 P/H
FE 850 P/H
FE 950 P/H

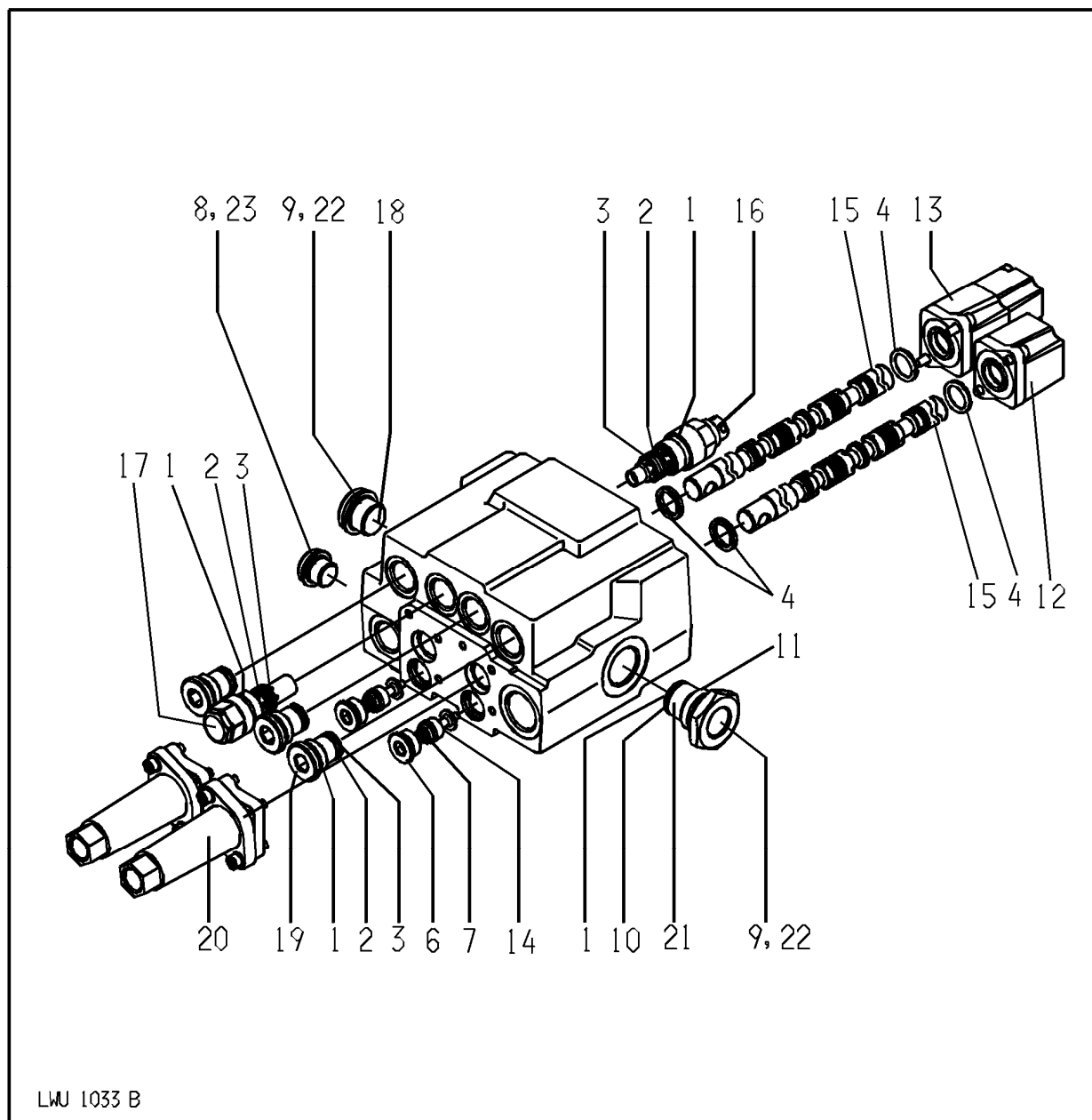

	LWU 1033	Dichtsatz für Wegeventil Nimco	Seal kit for control valve Nimco	Jeu de joints pour bloc de commande Nimco	STOLL FE		FE 650 P	FE 650 H	FE 750 P	FE 750 H	FE 850 P	FE 850 H	FE 950 P	FE 950 H
Pos.	Bestell-Nr.	Benennung	Description	Désignation	Zeichnungsnr.	SIZE/MASS								
A	0496470	Dichtsatz extern	Seal kit external	Jeu de joints externe		Nimco	1	1	1	1	1	1	1	1
1	-	O-Ring	O-Ring	Joint torique		17,3x2,4	5	5	5	5	5	5	5	5
2	-	Stützring	Supporting ring	Support de joint		Nimco 4S-4028	5	5	5	5	5	5	5	5
3	-	O-Ring	O-Ring	Joint torique		12,3x2,4	5	5	5	5	5	5	5	5
4	1419350	Dichtung für Steuerschieber	Sealing for control slide	Joint de glisseur			4	4	4	4	4	4	4	4
6	-	O-Ring	O-Ring	Joint torique		12,1x1,6	2	2	2	2	2	2	2	2
7	-	Dichtung	Sealing	Joint d'étanchéité		Nimco 4B-4523	2	2	2	2	2	2	2	2
8	-	Ring	Ring	Anneau		Nimco G 3/8"	1	1	1	1	1	1	1	1
9	-	Ring	Ring	Anneau		Nimco G 1/2"	2	2	2	2	2	2	2	2
10	-	Dichtung	Sealing	Joint d'étanchéité		Nimco 4B-4032	1	1	1	1	1	1	1	1
11	-	O-Ring	O-Ring	Joint torique		24,2x3	1	1	1	1	1	1	1	1
12	1423630	Schieber Kontrolle 1	Slide control 1	Tiroir controle 1			1	1	1	1	1	1	1	1
13	1423620	Schieber Kontrolle 2	Slide control 2	Tiroir controle 2		3/4"	1	1	1	1	1	1	1	1
14	1417130	Nachsaugventil	Suction valve	Valve		Nimco 4S-4549	2	2	2	2	2	2	2	2
15	3349910	Steuerschieber OC	Slide	Tiroir de commande		Nimco 3B-45115	2	2	2	2	2	2	2	2
15	3349920	Steuerschieber LS	Slide	Tiroir de commande		Nimco 3B-45116	2	2	2	2	2	2	2	2
16	1415800	Druckbegrenzungsventil, primär	pressure limiting valve, 1st	Limiteur de pression 1er		Nimco 4S-4029	1	1	1	1	1	1	1	1
17	0496330	Druckbegrenzungsventil, sekundär	pressure limiting valve, 2nd	Limiteur de pression 2ème		Nimco 4S-4030	1	1	1	1	1	1	1	1
18	1409200	Rückschlagventil Load Sensing	check valve	Valve anti retour		Nimco 4S-4748	1	1	1	1	1	1	1	1
19	1424990	Stopfen kpl.	Guard plug	Bouchon		Nimco 4S-4525	3	3	3	3	3	3	3	3
20	0488090	Schieberkappe	Slide cap	Couvercle		Nimco 4K-5118	1	1	1	1	1	1	1	1
21	1421380	Patrone für Druckweiterleitung	Cartridge, Carry over	Cartouche, retour libre		Nimco 4S-4031	3	3	3	3	3	3	3	3
22	0480040	Verschlußschraube	plug	Bouchon		3/4"	2	2	2	2	2	2	2	2
23	1595010	Verschlußschraube	plug	Bouchon		3/8"	1	1	1	1	1	1	1	1

STOLL FE

DE Dichtsatz für
Wegeventil Walvoil

FE 650 P/H
FE 750 P/H
FE 850 P/H
FE 950 P/H

EN Seal Kit for control
valve Walvoil

FE 650 P/H
FE 750 P/H
FE 850 P/H
FE 950 P/H

FR Jeu de joints pour bloc
de commande Walvoil

FE 650 P/H
FE 750 P/H
FE 850 P/H
FE 950 P/H

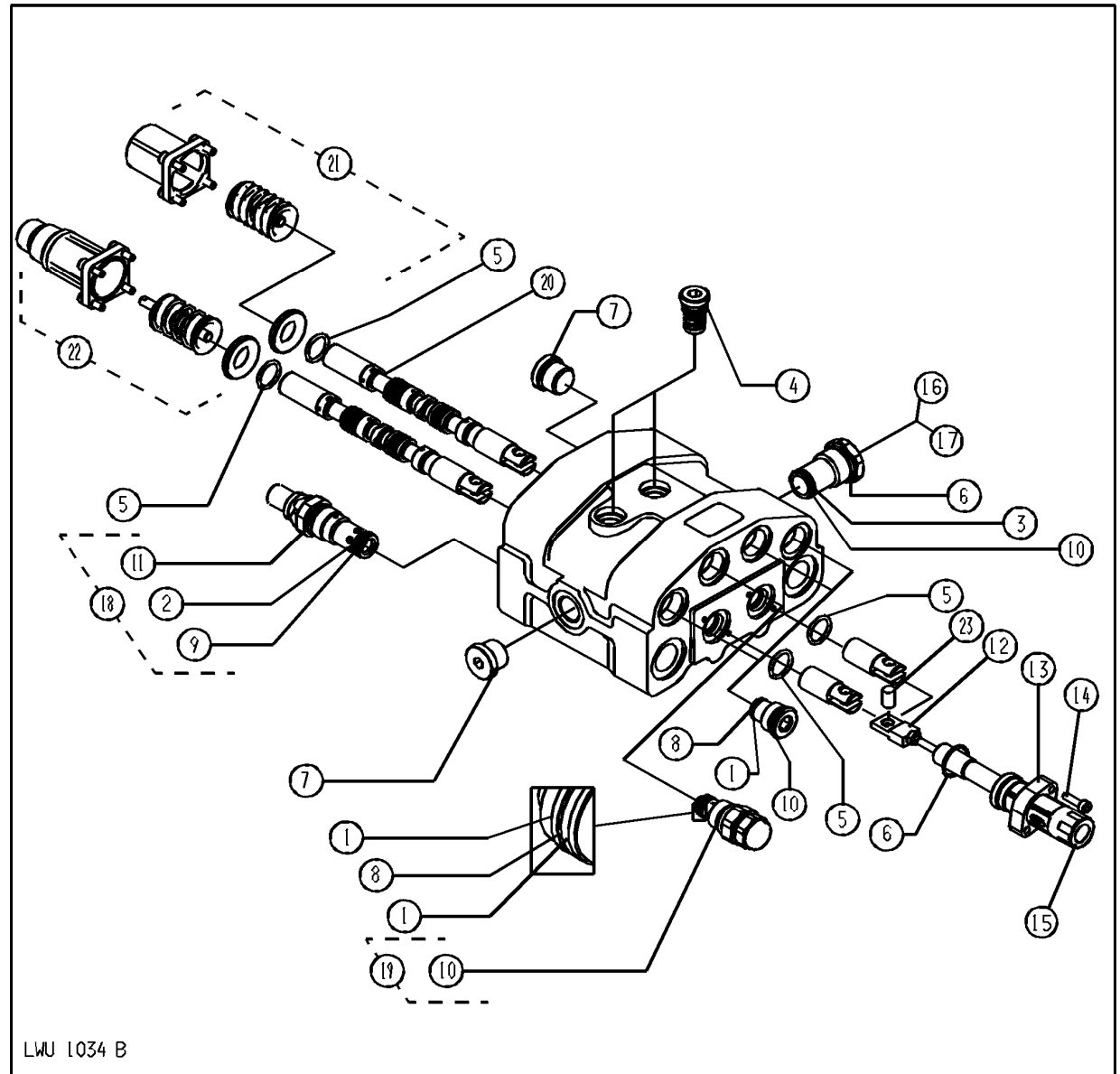

	LWU 1034	Dichtsatz für Wegeventil Walvoil	Seal Kit for control valve Walvoil	Jeu de joints pour bloc de commande Walvoil	STOLL FE		FE 650 P	FE 650 H	FE 750 P	FE 750 H	FE 850 P	FE 850 H	FE 950 P	FE 950 H
Pos.	Bestell-Nr.	Benennung	Description	Désignation	Zeichnungsnr.	SIZE/MASS								
A	3369270	Dichtsatz extern	Seal kit external	Jeu de joints externe		Walvoil	1	1	1	1	1	1	1	1
1		Stützring	Supporting ring	Support de joint		13,16x1,35	5	5	5	5	5	5	5	5
2		Stützring	Supporting ring	Support de joint		16,33x1,35	1	1	1	1	1	1	1	1
3		Stützring	Supporting ring	Support de joint		17,9x1,35	1	1	1	1	1	1	1	1
4		O-Ring	O-Ring	Joint torique		14x1,78	2	2	2	2	2	2	2	2
5	3369260	Dichtung für Steuerschieber	Sealing for control slide	Joint pour tiroir de commande			4	4	4	4	4	4	4	4
6		O-Ring	O-Ring	Joint torique		23,52x1,78	3	3	3	3	3	3	3	3
7		O-Ring	O-Ring	Joint torique		18,72x2,62	2	2	2	2	2	2	2	2
8		O-Ring	O-Ring	Joint torique		12,42x1,78	4	4	4	4	4	4	4	4
9		O-Ring	O-Ring	Joint torique		17,17x1,78	1	1	1	1	1	1	1	1
10		O-Ring	O-Ring	Joint torique		18,77x1,78	5	5	5	5	5	5	5	5
11		O-Ring	O-Ring	Joint torique		20,35x1,78	1	1	1	1	1	1	1	1
12	1422880	Lasche	Latch	Languette		Walvoil 3GIU413320	1	1	1	1	1	1	1	1
13	1424310	Flansch	Flange	Bride		Walvoil 3FLA135101	1	1	1	1	1	1	1	1
14	1424320	Schraube	Screw	Vis		Walvoil 4VIT605021	2	2	2	2	2	2	2	2
15	1422870	Kappe	Cap	Couvercle		Walvoil 3CAP430791	2	2	2	2	2	2	2	2
16	1424720	Patrone für Druckweiterleitung	Cartridge, carry over	Cartouche, retour libre		E/SDM11-SDM143-BSP1/2 Joint	1	1	1	1	1	1	1	1
17	0480040	Verschlußschraube	Plug	bouchon		VS-R 3/4 WD	1	1	1	1	1	1	1	1
18	1426460	Druckbegrenzungsventil, primär	pressure limiting valve, 1st	Limiteur de pression 1er		Walvoil X1234213190	1	1	1	1	1	1	1	1
19	1427420	Druckbegrenzungsventil, sekundär	pressure limiting valve, 2nd	Limiteur de pression 2ème		Walvoil X00515245	1	1	1	1	1	1	1	1
20	1431120	Steuerschieber OC	Slide	Tiroir de commande		Walvoil 3CU1310130	2	2	2	2	2	2	2	2
20	1431130	Steuerschieber LS	Slide	Tiroir de commande		Walvoil 3CU1310213	2	2	2	2	2	2	2	2
21	1431140	Schieber Kontrolle 1	Slide control 1	Tiroir controle 1		Walvoil 5V08108240	1	1	1	1	1	1	1	1
22	1431150	Schieber Kontrolle 2	Slide control 2	Tiroir controle 2		Walvoil 5V13108040	1	1	1	1	1	1	1	1
23	1431160	Zylinderstift	Parallel pin	Goupille de cylindre		Walvoil 3SPI108180	2	2	2	2	2	2	2	2

STOLL FE

DE Dichtsatz für
Wegeventil 45 l/min

FE 650 P/H
FE 750 P/H
FE 850 P/H
FE 950 P/H

EN Seal kit for control
valve 45 l/min

FE 650 P/H
FE 750 P/H
FE 850 P/H
FE 950 P/H

FR Jeu de joints pour bloc
de commande 45 l/min

FE 650 P/H
FE 750 P/H
FE 850 P/H
FE 950 P/H

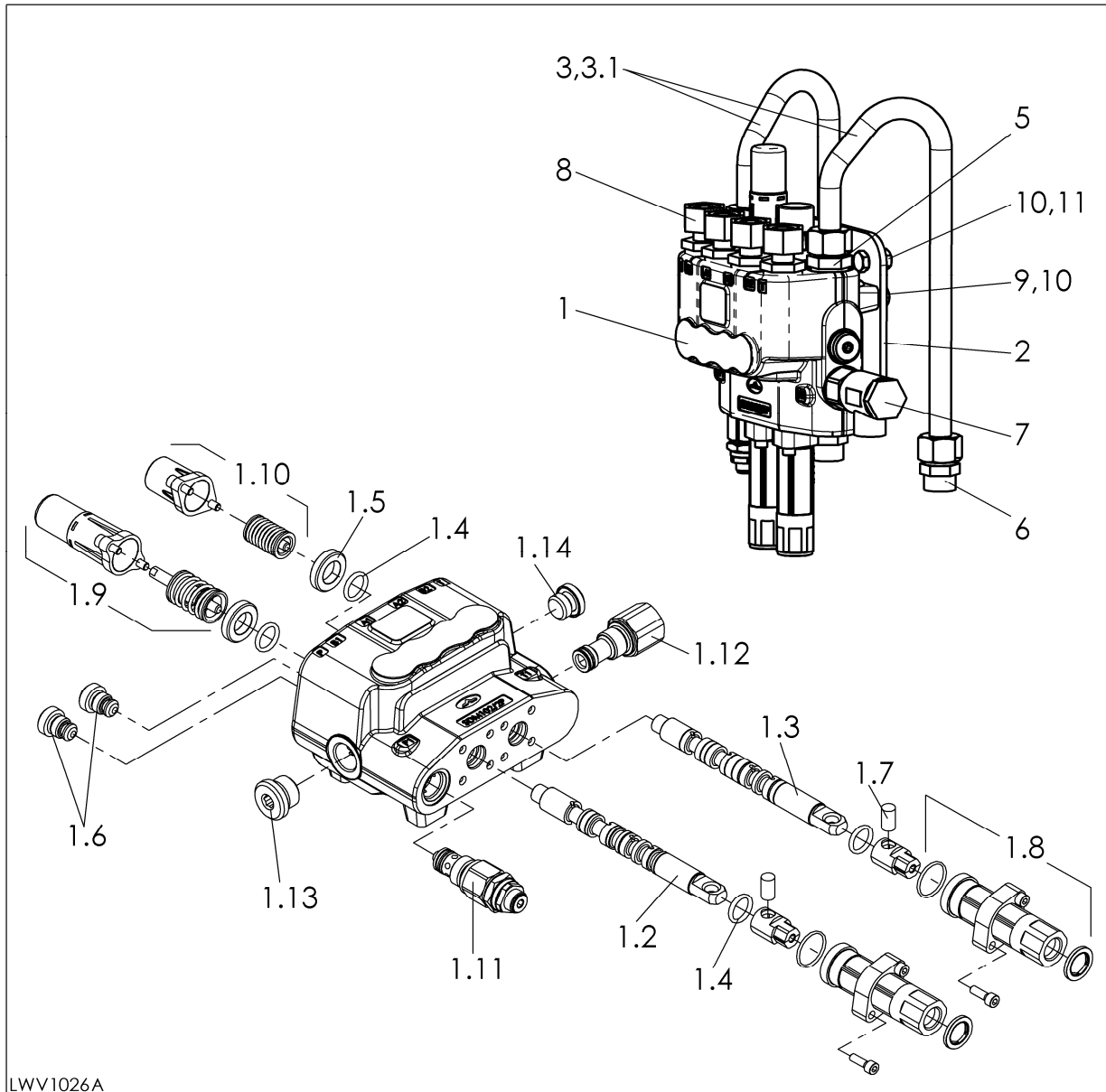

LWV1026A

	LWV 1026	Dichtsatz für Wegeventil 45 l/min	Seal kit for control valve 45 l/min	Jeu de joints pour bloc de commande 45 l/min	STOLL FE		FE 650 P	FE 650 H	FE 750 P	FE 750 H	FE 850 P	FE 850 H	FE 950 P	FE 950 H
Pos.	Bestell-Nr.	Benennung	Description	Désignation	Zeichnungsnr.	SIZE/MASS								
1	1430830	Wegeventil 45 l/min kpl.	Control valve 45 l/min cpl.	Bloc de commande 45 l/min cpl.	Walvoil SDM 102/2		1	1	1	1	1	1	1	1
1.2	1431440	Schieber 1	Slide	Tiroir de commande	3CU5242100		1	1	1	1	1	1	1	1
1.3	1431450	Schieber 2	Slide	Tiroir de commande	3CU5210100		1	1	1	1	1	1	1	1
1.4	1431460	O-Ring	O-Ring	Joint torique	15.88x2.62		4	4	4	4	4	4	4	4
1.5	1431470	Ring	Ring	Anneau	16x28x6		2	2	2	2	2	2	2	2
1.6	1431480	Verschlussstopfen	Plug	Bouchon			2	2	2	2	2	2	2	2
1.7	1431490	Zylinderstift	Parallel pin	Goupille de cylindre	9x18		2	2	2	2	2	2	2	2
1.8	1431500	Einstellkappe kpl.	Adjustable cap cpl	Chape réglable cpl			2	2	2	2	2	2	2	2
1.9	1431510	Schieberpositionierung 1	Slide control 1	Tiroir contrôle 1			1	1	1	1	1	1	1	1
1.10	1431520	Schieberpositionierung 2	Slide control 2	Tiroir contrôle 2			1	1	1	1	1	1	1	1
1.11	1431530	Druckbegrenzungsventil	Pressure limiting valve	Limiteur de pression	TG3-175		1	1	1	1	1	1	1	1
1.12	1431540	Patrone für Druckweiterleitung	Cartridge, carry over	Cartouche, retour libre			1	1	1	1	1	1	1	1
1.13	1431550	Verschlussstopfen	Plug	Bouchon	BSP 1/2		1	1	1	1	1	1	1	1
1.14	1431560	Verschlussstopfen	Plug	Bouchon	BSP 3/8		1	1	1	1	1	1	1	1
2	3478220	Adapterplatte	Adapter	Adaptateur	56.00-80-00.1		1	1	1	1	1	1	1	1
3	3478270	Hydraulikrohr kpl.	Pipe cpl.	Tuyau hydraulique cpl.	56.00-80-01		2	2	2	2	2	2	2	2
3.1	1429350	Weichdichtung	Captive seal ring	Joint mou	WALFORM 15 L		2	2	2	2	2	2	2	2
5	0427751	gerade Einschraubstutzen	Male stud coupling	Union simple mâle	WA GES 15 LR		2	2	2	2	2	2	2	2
6	0204061	gerade Stutzen	Straight coupling	Union double	WA GS 15 L		2	2	2	2	2	2	2	2
7	0427901	Winkelschwenkstutzen	Banjo coupling	Raccord orientable	WA RSWS 15 LR		1	1	1	1	1	1	1	1
8	0438861	gerade Einschraubverschraubung	Stud standpipe adaptor	Raccord d'orientation	WA EGESD 15LR-WD		4	4	4	4	4	4	4	4
9	0452140	Sicherheitsring	Safety ring	Bague de sécurité	HR 8		3	3	3	3	3	3	3	3
10	0011090	Sechskantschraube	Hex bolt	Vis	M 8x20		5	5	5	5	5	5	5	5
11	0011630	Sechskantmutter	Hex nut	Ecrou	M 8		2	2	2	2	2	2	2	2

STOLL FE

DE Einhebelsteuergerät

FE 650 P/H
 FE 750 P/H
 FE 850 P/H
 FE 950 P/H

EN Single-lever Control unit

FE 650 P/H
 FE 750 P/H
 FE 850 P/H
 FE 950 P/H

FR Monolevier

FE 650 P/H
 FE 750 P/H
 FE 850 P/H
 FE 950 P/H

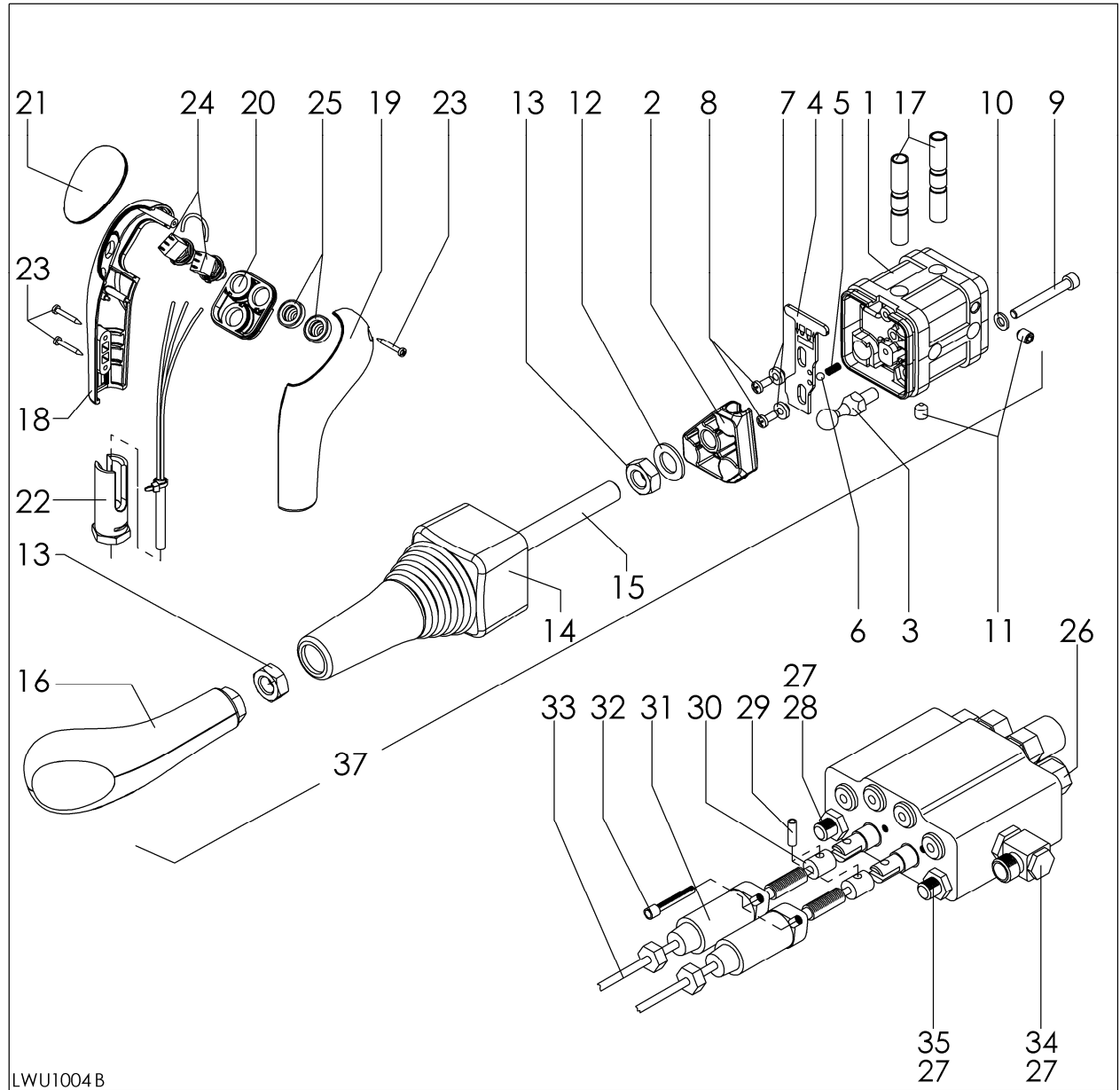

	LWU 1004	Einhebelsteuergerät	Single-lever Control unit	Monolevier	STOLL FE		FE 650 P	FE 650 H	FE 750 P	FE 750 H	FE 850 P	FE 850 H	FE 950 P	FE 950 H
Pos.	Bestell-Nr.	Benennung	Description	Désignation	Zeichnungsnr.	SIZE/MASS								
1	1429860	Gehäuse	Housing	Corps		NIMCO 11413-2	1	1	1	1	1	1	1	1
2	1429870	Gelenkkreuz-ALU	Articulating cross	Croix d'articulation		NIMCO 11367-3	1	1	1	1	1	1	1	1
3	1429880	Kugelkopf	Ball connection	Rotule		NIMCO 11368-4	1	1	1	1	1	1	1	1
4	1429890	Verriegelungsplatte	Locking plate	Plaque de verrouillage		NIMCO 11377-3	1	1	1	1	1	1	1	1
5	1429900	Arretierungsfeder	Spring	Ressort		NIMCO 11379-4	1	1	1	1	1	1	1	1
6	1429910	Arretierungskugel	Ball	Balle		NIMCO 800050	1	1	1	1	1	1	1	1
7	1429920	Führungsscheibe	Guiding disk	Rondelle		NIMCO 11416-4	2	2	2	2	2	2	2	2
8	1429930	Ejot-PT-Schraube	Ejot-PT-screw	Vis Ejot-PT		5,0x12	2	2	2	2	2	2	2	2
9	1406030	Zylinderschraube	Cylinder screw	Vis		M 6x50	1	1	1	1	1	1	1	1
10	0426680	Scheibe	Washer	Rondelle		A 6,4	1	1	1	1	1	1	1	1
11	1429940	Gewindestift	Threaded pin	Goujon fileté		M 8x10	2	2	2	2	2	2	2	2
12	0006550	Scheibe	Washer	Rondelle		R 14	1	1	1	1	1	1	1	1
13	1406610	Sechskantmutter	Hex nut	Écrou hexagonal en acier		BM 14x1,5	1	1	1	1	1	1	1	1
14	1429950	Faltenbalg	Bellows	Soufflet		NIMCO 11418-3	1	1	1	1	1	1	1	1
15	1429960	Stange	Rod	Barre		NIMCO 11382-4	1	1	1	1	1	1	1	1
16	1429980	Handgriff	Handle	Poignée		NIMCO 12016-3	1	1	1	1	1	1	1	1
17	1429970	Huelse	Hollow shaft	Douille		NIMCO 11415-4	2	2	2	2	2	2	2	2
18	1429990	Griffschale li	Lever Part left	Poignée Partie gauche		NIMCO 11966-3	1	1	1	1	1	1	1	1
19	1430000	Griffschale re	Lever Part right	Poignée Partie droite		NIMCO 11967-3	1	1	1	1	1	1	1	1
20	1430010	Tasterplatte 2 Taster	Plate 2 Push-buttons	Plaque 2 interrupteurs		NIMCO 12024-3	1	1	1	1	1	1	1	1
20	3462920	Tasterplatte 3 Taster	Plate 3 Push-buttons	Plaque 3 interrupteurs		NIMCO 12025-4	1	1	1	1	1	1	1	1
21	1430020	Symbolplatte	Symbol Plate	Plaque de Symbole		NIMCO 12022-4	1	1	1	1	1	1	1	1
22	1430030	Griffadapter	Adapter	Adaptateur		NIMCO 11376-4	1	1	1	1	1	1	1	1
23	1430040	Blechschrabe	Sheet metal screw	Vis Parker		B 2,9x22	2	2	2	2	2	2	2	2
24	0401090	Drucktaster	Push-button switch	Interrupteurs		NIMCO 4K-5117	2/3	2/3	2/3	2/3	2/3	2/3	2/3	2/3
25	1403580	Gummibalg für Drucktaster	Bellows for switch	Pressoir en caoutchouc		NIMCO 4K-5109	2/3	2/3	2/3	2/3	2/3	2/3	2/3	2/3
26	0438861	Gerader Einschraubstutzen	Screwed connection	Raccord droit		WA EGESD 15L	4	4	4	4	4	4	4	4
27	0467720	Schraubkappe	Screw cap	Chape a vis		M 22x1,5	3	3	3	3	3	3	3	3
28	0427751	Gerader Einschraubstutzen	Screwed connection	Raccord droit		GES 15 LR	1	1	1	1	1	1	1	1
29	0497550	Zylinderstift	Parallel pin	Goupille de cylindre		NHYDR	2	2	2	2	2	2	2	2
30	0492270	Buchse	Bush	Douille		NIMCO	2	2	2	2	2	2	2	2
31	0488090	Einstellkappe	Adjustable cap	Chape réglable		Nimco 4K-5118	2	2	2	2	2	2	2	2
32	2453910	Zylinderschraube	Cylinder screw	Vis a cylindre		M 5x55 (NHYDR)	2	2	2	2	2	2	2	2
33	0483170	Bowdenzug	Bowden wire	Câble téléflexible	56.00-36-01	1000mm	2	2	2	2	2	2	2	2
33	0485720	Bowdenzug	Bowden wire	Câble téléflexible	56.00-36-02	1200mm	2	2	2	2	2	2	2	2
33	0483180	Bowdenzug	Bowden wire	Câble téléflexible	56.00-36-03	1500mm	2	2	2	2	2	2	2	2
33	0485730	Bowdenzug	Bowden wire	Câble téléflexible	56.00-36-04	1600mm	2	2	2	2	2	2	2	2
33	0485740	Bowdenzug	Bowden wire	Câble téléflexible	56.00-36-05	1700mm	2	2	2	2	2	2	2	2
33	0494730	Bowdenzug	Bowden wire	Câble téléflexible	56.00-36-06	1850mm	2	2	2	2	2	2	2	2
33	0485750	Bowdenzug	Bowden wire	Câble téléflexible	56.00-36-07	2000mm	2	2	2	2	2	2	2	2
33	0485760	Bowdenzug	Bowden wire	Câble téléflexible	56.00-36-08	2200mm	2	2	2	2	2	2	2	2
33	0485710	Bowdenzug	Bowden wire	Câble téléflexible	56.00-36-09	2500mm	2	2	2	2	2	2	2	2
33	3331130	Bowdenzug	Bowden wire	Câble téléflexible	56.00-36-10	2800mm	2	2	2	2	2	2	2	2
34	0427901	Drosselfr. Winkelschwenkstutzen	Elbow connection	Raccord coudé		RSWS 15 LR	1	1	1	1	1	1	1	1
35	0478280	Gerader Einschraubstutzen	Screwed connection	Raccord droit		GES 15 LR 3/4"	1	1	1	1	1	1	1	1
37	3462730	Bedienungshebel kpl.	Joy-Strick cpl.	Monolevier complet	56.00-23-01		1	1	1	1	1	1	1	1
38	3478660	Nachrüstung Drucktaster WK300	Backfitting Push-button switch WK300	Armement additionnel Interrupteurs WK300	56.09-104-09		1	1	1	1	1	1	1	1

STOLL FE

DE Ausrüstung Comfort-Drive

FE 650 P/H
FE 750 P/H
FE 850 P/H
FE 950 P/H

EN Kit Comfort-Drive

FE 650 P/H
FE 750 P/H
FE 850 P/H
FE 950 P/H

FR Comfort-Drive équipement

FE 650 P/H
FE 750 P/H
FE 850 P/H
FE 950 P/H

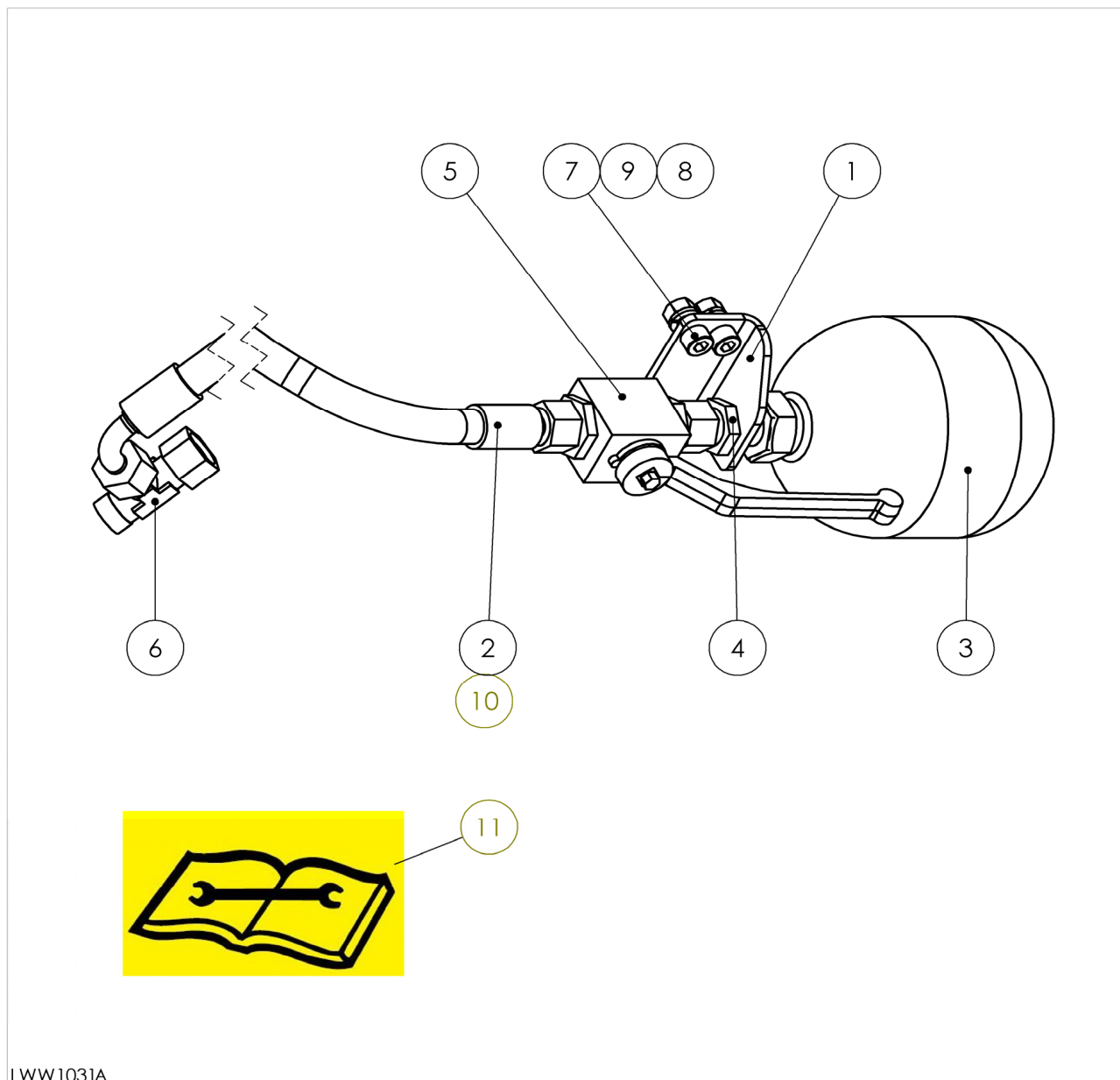

LWW1031A

	LWW1031	Ausrüstung Comfort-Drive	Kit Comfort-Drive	Comfort-Drive équipement	STOLL FE		FE 650 P	FE 650 H	FE 750 P	FE 750 H	FE 850 P	FE 850 H	FE 950 P	FE 950 H
Pos.	Bestell-Nr.	Benennung	Description	Désignation	Zeichnungsnr.	SIZE/MASS								
1	3310400	Halter	Support	Support	58.513-00.1		1	1	1	1	1	1	1	1
2	3506930	Schlauchleitung	Hose	Flexible	1SN N RKN90 - 08x1200 - M18x1,5		1	1	1	1	1	1	1	1
3	3506940	Membranspeicher	Accumulator	Accumulateur hydraulique	Hydac SBO210-0,5E2\663U-20bar		1	1	1	1	1	1	1	1
4	1408850	Schottstutzen	Connection	Raccord	GES G1\2 A-12L		1	1	1	1	1	1	1	1
5	1520060	Absperrventil	Break valve	Soupape d'arret	48.16-21 (DN10)		1	1	1	1	1	1	1	1
6	0401931	einstellbare L-Verschraubung	L-Connection	Raccord-L	WA ELSD 12 L		1	1	1	1	1	1	1	1
7	1415700	Zylinderschraube	Cylinder screw	Vis a cylindre	ISO 4762 M8 x 20		2	2	2	2	2	2	2	2
8	0011630	Sechskantmutter	Hex nut	Ecrou	Hexagon Nut ISO - 4032 - M8		2	2	2	2	2	2	2	2
9	0452140	Sicherheitsring	Safety ring	Bague de securité	Federring DIN 127 - A 08 ZN		2	2	2	2	2	2	2	2
10	0434820	Kabelbinder	Strap	Borne de jonction	4,8 x 188		4	4	4	4	4	4	4	4
11	1432670	Aufkleber	Decal	Autocollant			1	1	1	1	1	1	1	1
12	3507140	Montageanleitung	Assembly instructions	Notice de montage	A 2049		1	1	1	1	1	1	1	1

STOLL FE

DE Hydraulik-Ausrüstung
3. Steuerkreis

EN Hydraulik Equipment
3rd Function

FR Equipement
hydraulique
3ème Fonction

FE 650 P/H
FE 750 P/H
FE 850 P/H
FE 950 P/H

FE 650 P/H
FE 750 P/H
FE 850 P/H
FE 950 P/H

FE 650 P/H
FE 750 P/H
FE 850 P/H
FE 950 P/H

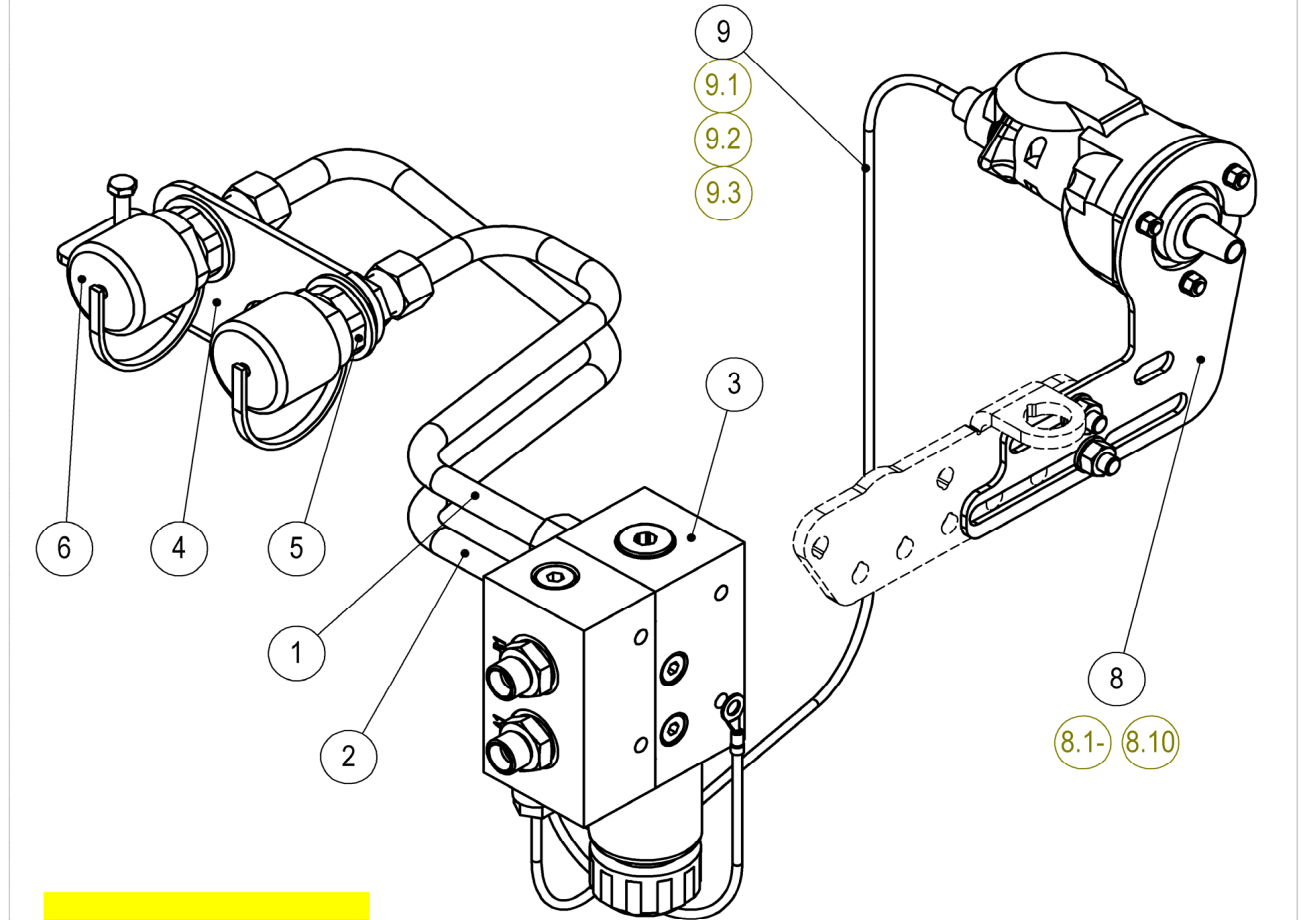

LWW1032B

	LWW1032	Hydraulik-Ausrüstung 3. Steuerkreis	Hydraulik Equipment 3rd Function	Equipement hydraulique 3ème Fonction	STOLL FE		FE 650 P	FE 650 H	FE 750 P	FE 750 H	FE 850 P	FE 850 H	FE 950 P	FE 950 H
Pos.	Bestell-Nr.	Benennung	Description	Désignation	Zeichnungsnr.	SIZE/MASS								
1	3500710	Hydraulikrohr	Pipe	Tuyau hydraulique	58.800-19-10		1	1	1	1	1	1	1	1
1.1	1429340	Dichtung	Seal ring	Bague d'étanchéité		Walform 12L	4	4	4	4	4	4	4	4
2	3500720	Hydraulikrohr	Pipe	Tuyau hydraulique	58.800-19-11		1	1	1	1	1	1	1	1
3	3501770	Ventil	Valve	Valve	58.800-19-21		1	1	1	1	1	1	1	1
4	3505220	Halter	Support	Support	58.800-19-00.10		2	2	2	2	2	2	2	2
5	0416570	Kuppelmuffe	Quick-Coupler (female part)	Manchon d'embrayage		VOSW HS10-	2	2	2	2	2	2	2	2
6	0418490	Schutzkappe	Protective cap	Capuchon protecteur		TCH 63 6591	1	1	1	1	1	1	1	1
7	1430450	Sechskantschraube	Hex bolt	Vis		ISO 4017 - M6	1	1	1	1	1	1	1	1
8	3456090	Steckdose kpl.	Socket cpl	Prise de Courant cpl	58.725-25-10		1	1	1	1	1	1	1	1
8.1	3408960	Steckdosenblech	Support for socket	Support pour prise de courant	58.636-01-00.1		1	1	1	1	1	1	1	1
8.2	0445630	Steckdose 7polig	Socket	Prise de courant 7 broches	58.636-01-00.1		1	1	1	1	1	1	1	1
8.3	1429520	Dichtung für Steckdose 7polig	Sealing for socket	Joint pour prise de courant 7 broches		8JB001	1	1	1	1	1	1	1	1
8.4	0445640	Kabelbinder	Connector	Connexion		9GD735	3	3	3	3	3	3	3	3
8.5	0407390	Sechskantmutter Muffe 5	Nut	Ecrou		4,8 x 188	3	3	3	3	3	3	3	3
8.6	0452120	Sicherheitsring	Circlip	Circlip		M 5	3	3	3	3	3	3	3	3
8.7	0011110	Sechskantschraube Muffe 8x25	Screw	Vis		5	2	2	2	2	2	2	2	2
8.8	0011630	Sechskantmutter Muffe 8	Nut	Ecrou		M 8x25	2	2	2	2	2	2	2	2
8.9	0407070	Scheibe	Washer	Rondelle		M 8	2	2	2	2	2	2	2	2
8.10	0452140	Sicherheitsring	Safety ring	Bague de sécurité		9	2	2	2	2	2	2	2	2
9	3505200	Kabel kpl	Electric cable cpl	Câble électrique cpl	58.800-19-25-01	8	1	1	1	1	1	1	1	1
9.1	0488650	Gerätesteckdose	Socket	Prise de Courant		GDM 3009SW	1	1	1	1	1	1	1	1
9.2	0450550	Dichtung	Sealing	Joint		180916	1	1	1	1	1	1	1	1
9.3	0453680	Kabelschuh	Eyelet	Cosse de Câble		8 - 1,0	1	1	1	1	1	1	1	1
9.4	0407220	Stecker 7polig	Plug 7pin	Fiche 7broches		8JA001	1	1	1	1	1	1	1	1
11	3507130	Montageanleitung	Assembly instructions	Notice de montage		A 2048	1	1	1	1	1	1	1	1

STOLL FE

DE Elektroausrüstung FE

FE 650 P/H
FE 750 P/H
FE 850 P/H
FE 950 P/H

EN Electrical equipment FE

FE 650 P/H
FE 750 P/H
FE 850 P/H
FE 950 P/H

FR Equipement électrique FE

FE 650 P/H
FE 750 P/H
FE 850 P/H
FE 950 P/H

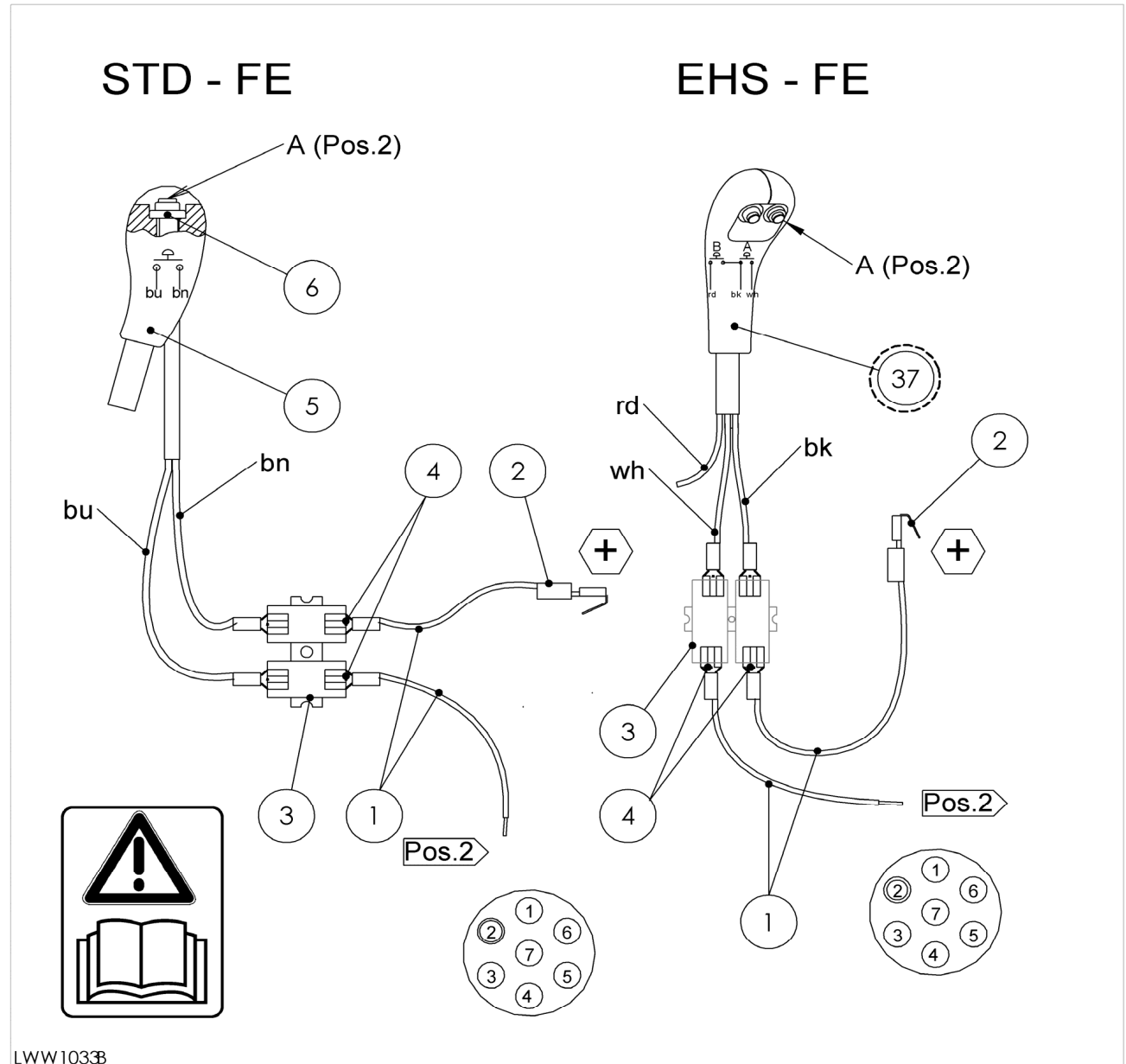

	LWW1033	Elektroausrüstung FE	Electrical equipment FE	Equipement électrique FE	STOLL FE		FE 650 P	FE 650 H	FE 750 P	FE 750 H	FE 850 P	FE 850 H	FE 950 P	FE 950 H
Pos.	Bestell-Nr.	Benennung	Description	Désignation	Zeichnungsnr.	SIZE/MASS								
1	1317940	Kabel kpl	Electric cable cpl	Câble électrique cpl	58.35-01-05		2	2	2	2	2	2	2	2
2	0413710	Steckverteiler	Push-on Junction	Connexion	DRUS 01118	6,3-2,5 BLAU	1	1	1	1	1	1	1	1
3	0437460	Flachsteckkupplung	Flat plug coupling	Coupleur de fiche mâle	03755	2/12 6,3X0,8X28 2POL	1	1	1	1	1	1	1	1
4	0207690	Steckhülse	Push-on contact	Connexion		ROT 6,3-1,0 D 46	2	2	2	2	2	2	2	2
5	1349130	Steuerhebel	Joy-stick	Monolevier	58.33-05-00.1		1	1	1	1	1	1	1	1
6	1349140	Drucktaster kpl.	Push-button switch cpl.	Interrupteur complet	58.33-05-01		1	1	1	1	1	1	1	1
8	3505260	Montageanleitung	Assembly instructions	Notice de montage		A 2041	1	1	1	1	1	1	1	1

STOLL FE

DE Aufkleber
Anleitung

EN Decal Manual

FR Autocollants
Instruction

FE 650 P/H
FE 750 P/H
FE 850 P/H
FE 950 P/H

FE 650 P/H
FE 750 P/H
FE 850 P/H
FE 950 P/H

FE 650 P/H
FE 750 P/H
FE 850 P/H
FE 950 P/H

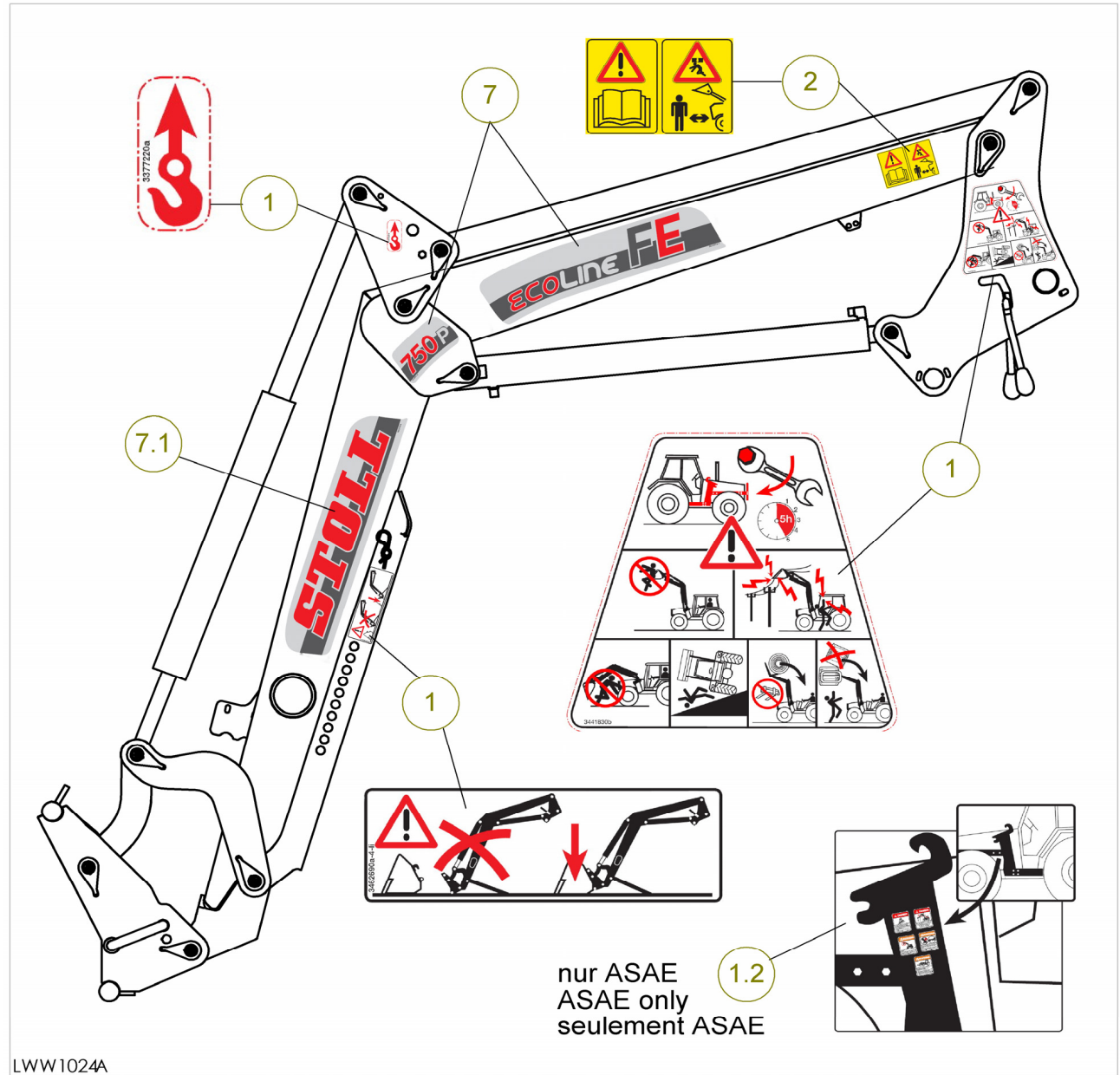

	LWW 1024	Aufkleber Anleitung	Decal Manual	Autocollants Instruction	STOLL FE		FE 650 P	FE 650 H	FE 750 P	FE 750 H	FE 850 P	FE 850 H	FE 950 P	FE 950 H
Pos.	Bestell-Nr.	Benennung	Description	Désignation	Zeichnungsnr.	SIZE/MASS								
1	3462690	Aufklebersatz Technik für Europa: EU-Länder	Kit decals "Technics" for Europe: EC-countries	Kit d'autocollants "technique" pour Europe: pays membre UE			1	1	1	1	1	1	1	1
1	3480690	Aufklebersatz Technik ASAE	Kit decals "Technics ASAE"	Kit d'autocollants "technique ASAE"			1	1	1	1	1	1	1	1
1.2	3395850	Aufklebersatz "Safety ASAE" nur im Bereich der ASAE USA Kanada Neuseeland Australien	Kit decals "Safety ASAE" ASAE-states only USA Canada NewZealand Australien	Kit d'autocollants "Safety ASAE" seulement pour les payes ASAE standar USA Canada NouvelleZélande Australie			1	1	1	1	1	1	1	1
2	3431550	Aufkleber Technik	Decal "Technics"	Autocollant "technique"			1	1	1	1	1	1	1	1
2.1	3484230	Aufklebersatz Technik ASAE	Kit decals "Technics ASAE"	Kit d'autocollants "technique ASAE"			1	1	1	1	1	1	1	1
3	3449070	Aufkleber Kabine	Decal "Cabin"	Autocollant "cabine"			1	1	1	1	1	1	1	1
7	3503750	Ausrüstung Logo FE 650 P	Kit decals FE 650 P	Jeu d'autocollants FE 650 P	58.804-40-01		1							
7.1	3503590	Ausrüstung Logo FE	Kit decals FE	Jeu d'autocollants FE	58.800-40-03		1	1	1	1	1	1	1	1
7	3504110	Ausrüstung Logo FE 650 H	Kit decals FE 650 H	Jeu d'autocollants FE 650 H	58.805-40-01			1						
7	3503580	Ausrüstung Logo FE 750 P	Kit decals FE 750 P	Jeu d'autocollants FE 750 P	58.800-40-01				1					
7	3504170	Ausrüstung Logo FE 750 H	Kit decals FE 750 H	Jeu d'autocollants FE 750 H	58.801-40-01				1					
7	3503880	Ausrüstung Logo FE 850 P	Kit decals FE 850 P	Jeu d'autocollants FE 850 P	58.810-40-01					1				
7	3504280	Ausrüstung Logo FE 850 H	Kit decals FE 850 H	Jeu d'autocollants FE 850 H	58.811-40-01						1			
7	3503950	Ausrüstung Logo FE 950 P	Kit decals FE 950 P	Jeu d'autocollants FE 950 P	58.820-40-01								1	
7	3504330	Ausrüstung Logo FE 950 H	Kit decals FE 950 H	Jeu d'autocollants FE 950 H	58.821-40-01									1
8	3513960	Betriebsanleitung	-	-			1	1	1	1	1	1	1	1
8	3513970	-	Operator's manual	-			1	1	1	1	1	1	1	1
8	3513980	-	-	Livret d'utilisation			1	1	1	1	1	1	1	1
10	1430810	Sprühdose Schwarz-Grau	Aerosol can black-grey	Bombe aérosol noir-grise			x	x	x	x	x	x	x	x
10	1429780	Farbdose Schwarz-Grau	Paint can black-grey	Boîte couleur noir-grise			x	x	x	x	x	x	x	x

STOLL FE

DE Aufkleber
Anleitung

FE 650 P/H
FE 750 P/H
FE 850 P/H
FE 950 P/H

EN Decal Manual

FE 650 P/H
FE 750 P/H
FE 850 P/H
FE 950 P/H

FR Autocollants
Instruction

FE 650 P/H
FE 750 P/H
FE 850 P/H
FE 950 P/H

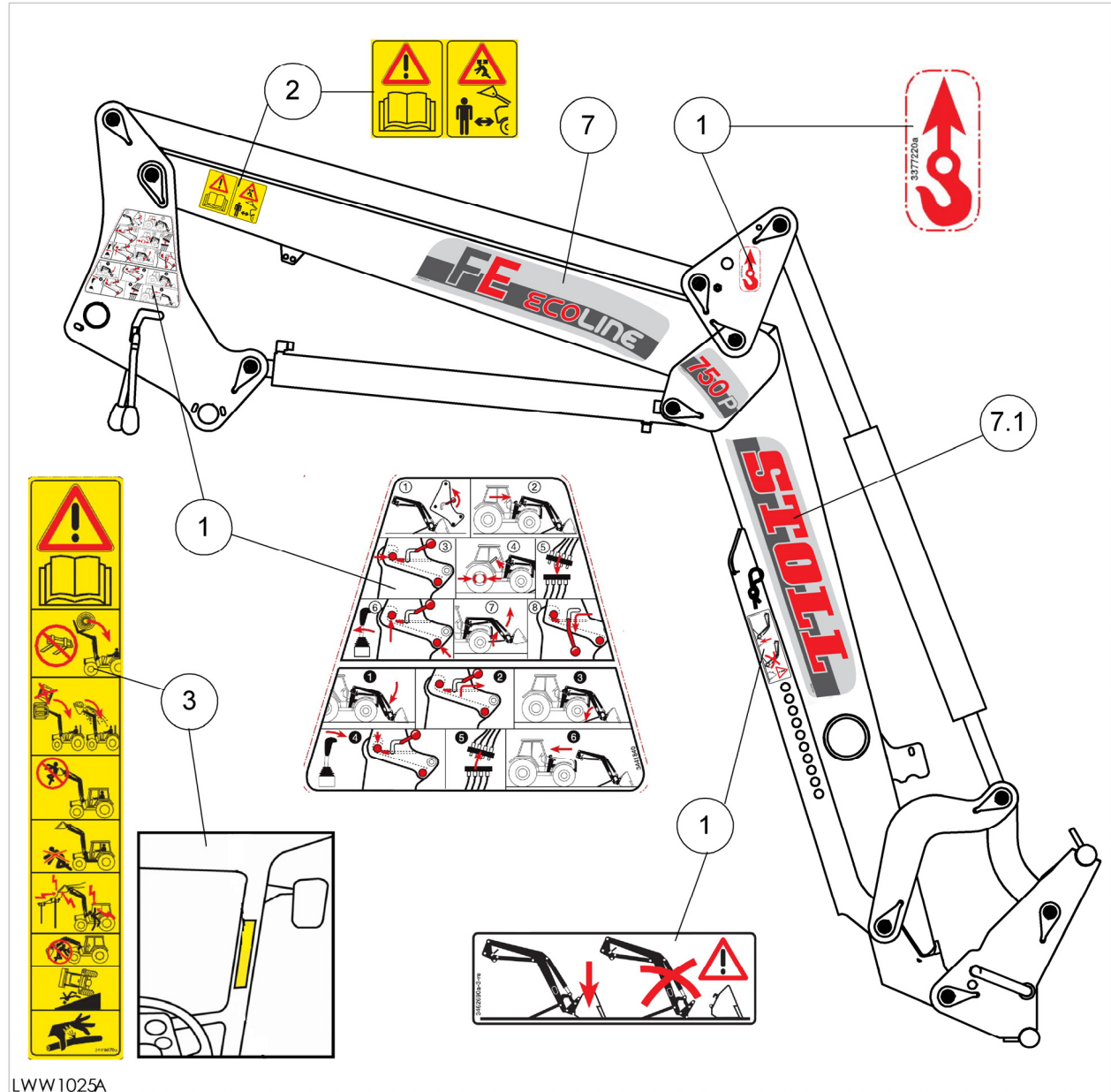

LWW1025A

	LWW 1024	Aufkleber Anleitung	Decal Manual	Autocollants Instruction	STOLL FE		FE 650 P	FE 650 H	FE 750 P	FE 750 H	FE 850 P	FE 850 H	FE 950 P	FE 950 H
Pos.	Bestell-Nr.	Benennung	Description	Désignation	Zeichnungsnr.	SIZE/MASS								
1	3462690	Aufklebersatz Technik für Europa: EU-Länder	Kit decals "Technics" for Europe: EC-countries	Kit d'autocollants "technique" pour Europe: pays membre UE			1	1	1	1	1	1	1	1
1	3480690	Aufklebersatz Technik ASAE	Kit decals "Technics ASAE"	Kit d'autocollants "technique ASAE"			1	1	1	1	1	1	1	1
1.2	3395850	Aufklebersatz "Safety ASAE" nur im Bereich der ASAE USA Kanada Neuseeland Australien	Kit decals "Safety ASAE" ASAE-states only USA Canada NewZealand Australien	Kit d'autocollants "Safety ASAE" seulement pour les payes ASAE standar USA Canada NouvelleZélande Australie			1	1	1	1	1	1	1	1
2	3431550	Aufkleber Technik	Decal "Technics"	Autocollant "technique"			1	1	1	1	1	1	1	1
2.1	3484230	Aufklebersatz Technik ASAE	Kit decals "Technics ASAE"	Kit d'autocollants "technique ASAE"			1	1	1	1	1	1	1	1
3	3449070	Aufkleber Kabine	Decal "Cabin"	Autocollant "cabine"			1	1	1	1	1	1	1	1
7	3503750	Ausrüstung Logo FE 650 P	Kit decals FE 650 P	Jeu d'autocollants FE 650 P	58.804-40-01		1							
7.1	3503590	Ausrüstung Logo FE	Kit decals FE	Jeu d'autocollants FE	58.800-40-03		1	1	1	1	1	1	1	1
7	3504110	Ausrüstung Logo FE 650 H	Kit decals FE 650 H	Jeu d'autocollants FE 650 H	58.805-40-01			1						
7	3503580	Ausrüstung Logo FE 750 P	Kit decals FE 750 P	Jeu d'autocollants FE 750 P	58.800-40-01				1					
7	3504170	Ausrüstung Logo FE 750 H	Kit decals FE 750 H	Jeu d'autocollants FE 750 H	58.801-40-01				1					
7	3503880	Ausrüstung Logo FE 850 P	Kit decals FE 850 P	Jeu d'autocollants FE 850 P	58.810-40-01					1				
7	3504280	Ausrüstung Logo FE 850 H	Kit decals FE 850 H	Jeu d'autocollants FE 850 H	58.811-40-01						1			
7	3503950	Ausrüstung Logo FE 950 P	Kit decals FE 950 P	Jeu d'autocollants FE 950 P	58.820-40-01								1	
7	3504330	Ausrüstung Logo FE 950 H	Kit decals FE 950 H	Jeu d'autocollants FE 950 H	58.821-40-01									1
8	3513960	Betriebsanleitung	-	-			1	1	1	1	1	1	1	1
8	3513970	-	Operator's manual	-			1	1	1	1	1	1	1	1
8	3513980	-	-	Livret d'utilisation			1	1	1	1	1	1	1	1
10	1430810	Sprühdose Schwarz-Grau	Aerosol can black-grey	Bombe aérosol noir-grise			x	x	x	x	x	x	x	x
10	1429780	Farbdose Schwarz-Grau	Paint can black-grey	Boîte couleur noir-grise			x	x	x	x	x	x	x	x

Wilhelm STOLL
Maschinenfabrik GmbH

Bahnhofstr. 21

D-38266 Lengede

Ersatzteilbestellung / Spare parts order / Commande des pièces:

Tel.: +49 (0) 53 44 / 20 444

Fax: +49 (0) 53 44 / 20 183

E-mail: ea@stoll-germany.com

Öffnungszeiten / business hours / heures d'ouverture:

Mo - Do / Mon - Thu / Lu - Je: 8:00 - 11:45 + 12:15 - 17:00

Fr / Fri / Ve: 8:00 - 11:45 + 12:15 - 16:00

Weitere Kontakte / further contacts / autres contacts:

Tel. Kundendienst / service / service:

+49 (0) 5344 / 20 111

Fax Kundendienst / service / service:

+49 (0) 5344 / 20 137

E-mail Kundendienst / service / service:

service@stoll-germany.com

Fax Vertrieb / sales / vente:

+49 (0) 5344 / 20 49182

E-mail Vertrieb / sales / vente:

verkauf@stoll-germany.com

E-Mail allgemein / general / général:

info@stoll-germany.com